



Serie 2500

Porte
Doors



Meccanismo per porte pieghevoli, divise in due parti diverse.

Folding doors equipment, divided in two different parts.

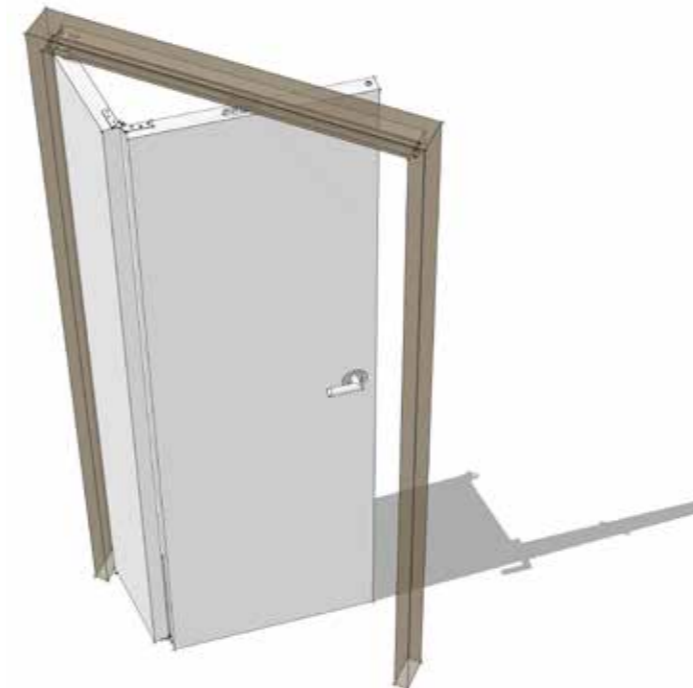

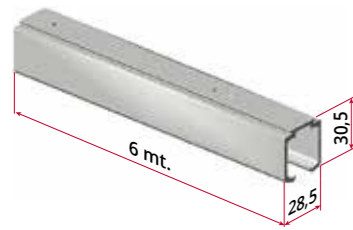

art. 2201
Binario in alluminio, forato e asolato
Aluminium rail, punched

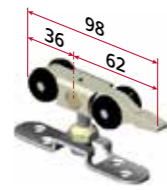

art. 2208
Carrello in nylon, regolabile con staffa 2200
Nylon carriage adjustable with 2200 bracket



art. 3103
Carrello nylon con 2 cuscinetti a sfera
2-ball bearings nylon truck

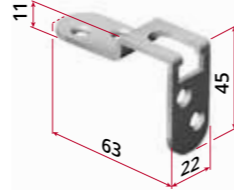

art. 3105
per/for art. 3103
Staffa angolare per carrello
Corner bracket for truck

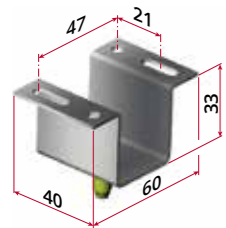

art. 2502
Staffa acciaio con cardine superiore
Steel bracket with upper pivot

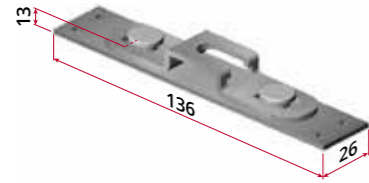

art. 2200-2500
Staffa incassabile
Embedded bracket

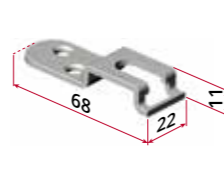

art. 3102
per/for art. 3103
Staffa incassabile per carrello
Embedded bracket for truck



art. 2503
Fermo di chiusura con molla
Closer stopper with spring

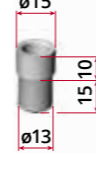

art. 2504
per/for art. 2501
Distanziale per bussola
Spacer for bush

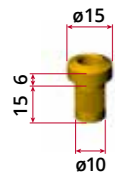

art. 2501
Bussola in ottone per cardini
Brass bush for pivots

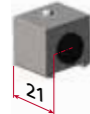

art. 2467
Fermo finecorsa in nylon con para colpi
Nylon end-run stop with bumper

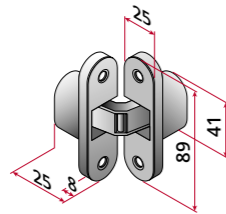

art. 2525
Cerniera invisibile in acciaio e nylon
Invisible nylon and steel hinge

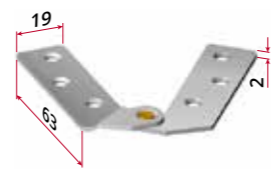

art. 2519
Cerniera in acciaio
Steel hinge

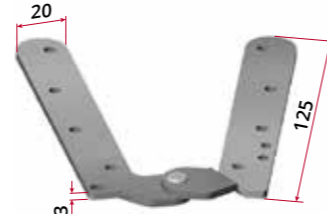

art. 5203
Cerniera in acciaio
Steel hinge

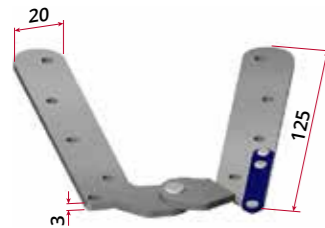

art. 5203/M
Cerniera in acciaio con molla
Steel hinge with spring



art. 2204
Chiave fissa 8/16 mm
Fix key 8/16 mm



art. 3104
Cardine superiore a scomparsa, regolabile
Adjustable embedded upper pivot

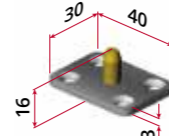

art. 2505
Cardine inferiore per fissaggio a pavimento
Floor fixing lower pivot

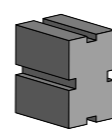

art. 220
per/for art. 2201
Spugna pulisci binario
Cleaner rails sponge

Tabella di calcolo per la larghezza della porta | Calculation list of door width

Proporzione fra le due parti

La larghezza della parte «L» potrà variare ma dovrà essere almeno 100 mm più lunga della parte «F», rispettando la mezzeria tra bussola ottone e staffa carrello.

Two-parts division

Door width of side «L» shall be change but will be minimum 100 mm longer of side «F», according the middling line between brass bush and truck bracket.

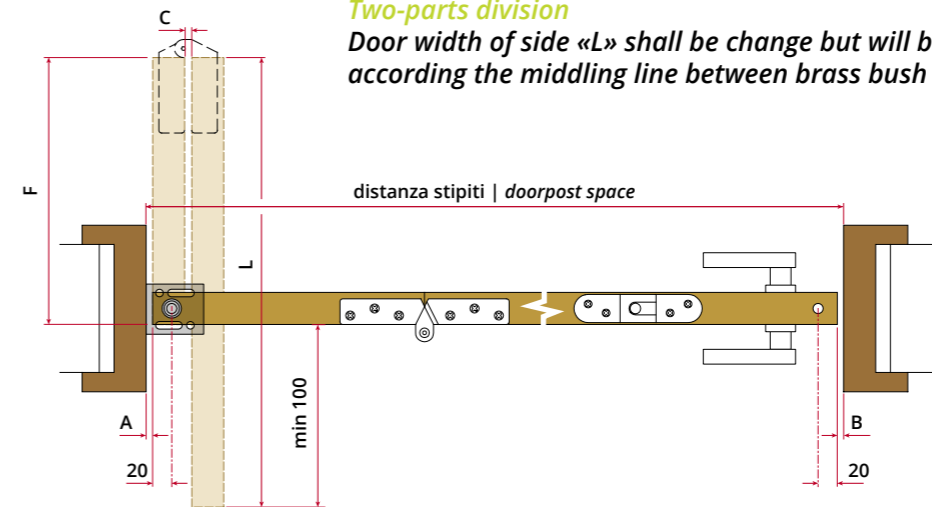

spessore anta door thickness	A	B	C per/for art.	
			2519	5203
22 mm	5 mm	3 mm	Max 11 mm	Max 28 mm
30 mm	6 mm			
35 mm	8 mm			
40 mm	10 mm			
45 mm	12 mm			

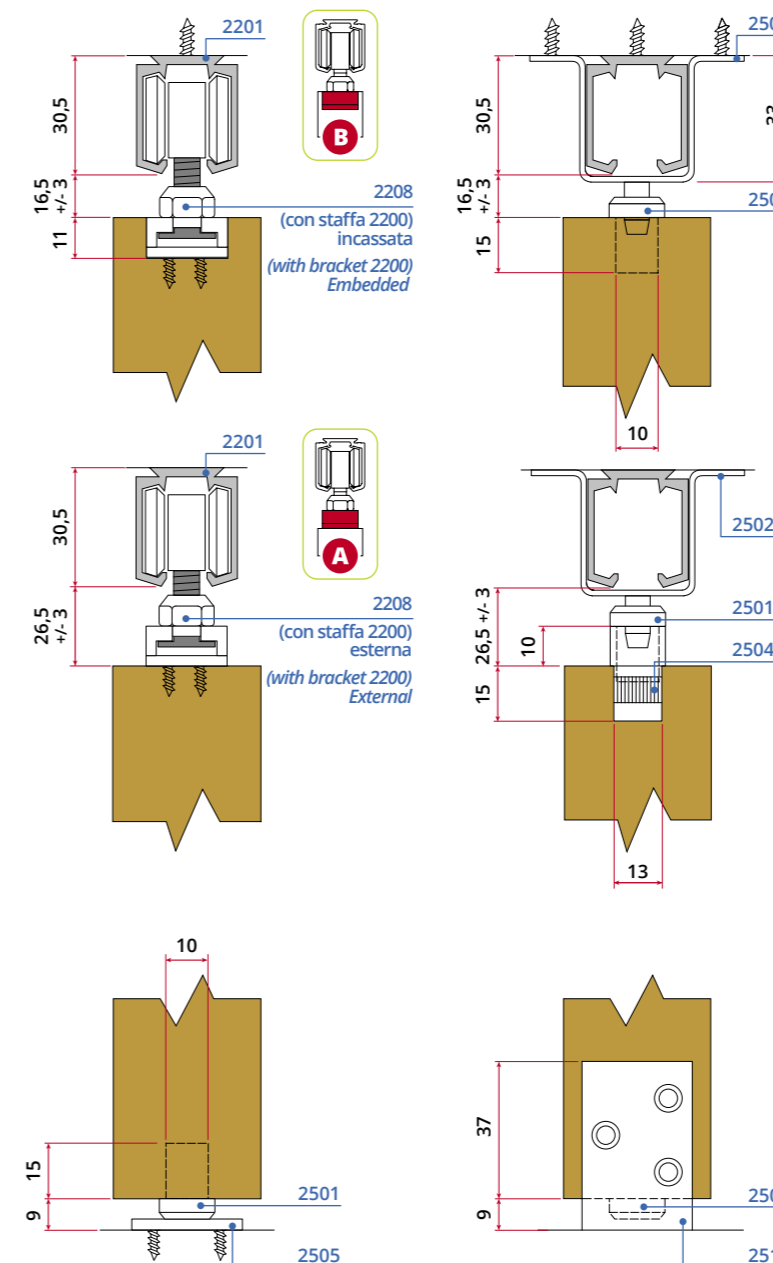

È possibile fissare i carrelli con staffe non incassate, utilizzando il distanziale (art. 2504).

It is possible fix trucks with not embedded bracket, using spacer (art. 2504).

Cardini inferiori.
Art. 2505 + 2501 oppure 2510 + 2501

Lower pivots.
Art. 2505 + 2501 or 2510 + 2501

Informazioni tecniche | Technical informations

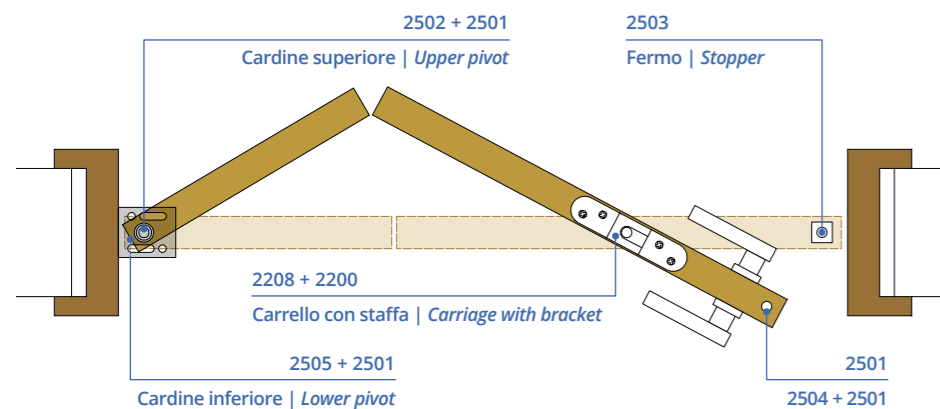

Caratteristiche serie 2500
Meccanismo per porta pieghevole a 2 pannelli, e apertura con maniglia tradizionale.

Series 2500 Features
Mechanism for two-panels folding door, with traditional hinge opening.

Istruzioni montaggio | Assembly instructions

Cerniere | Hinges

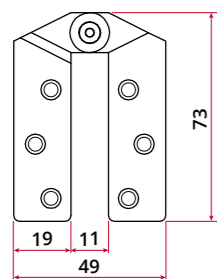

art. 2519
Cerniera acciaio portata 50kg a coppia.
Steel hinge with capacity 50kg per couple.

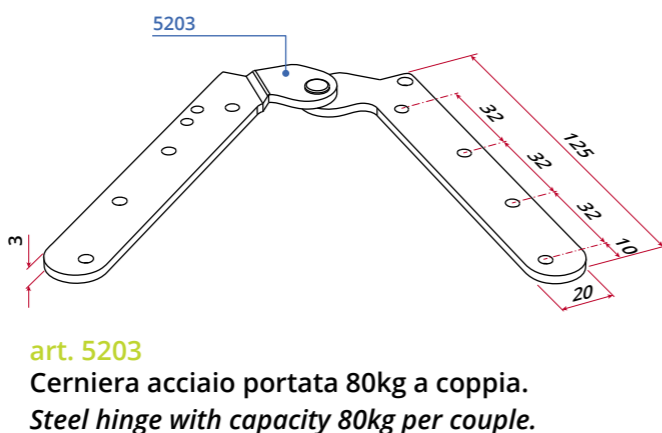
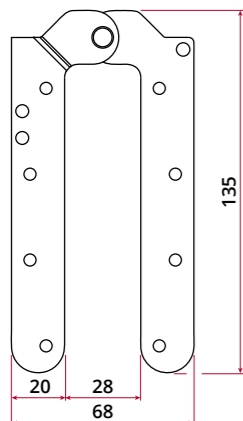

art. 5203
Cerniera acciaio portata 80kg a coppia.
Steel hinge with capacity 80kg per couple.

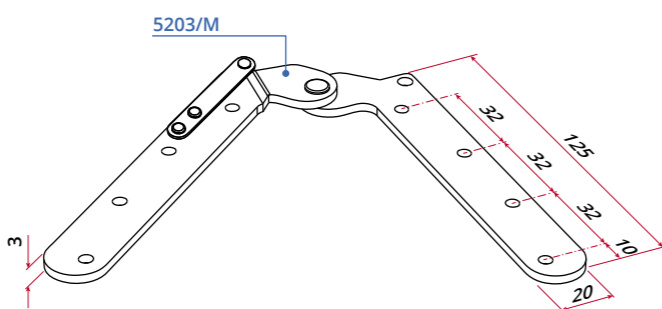
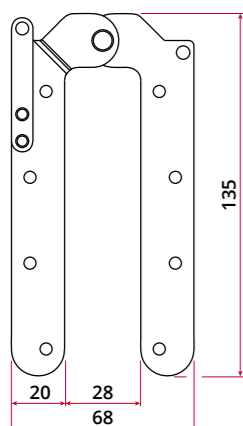

art. 5203/M
Cerniera acciaio portata 80kg a coppia con molla a scatto per l'allineamento di chiusura.
Steel hinge with capacity 80kg per couple equipped with alignment click.

Montaggio porta | Door mounting

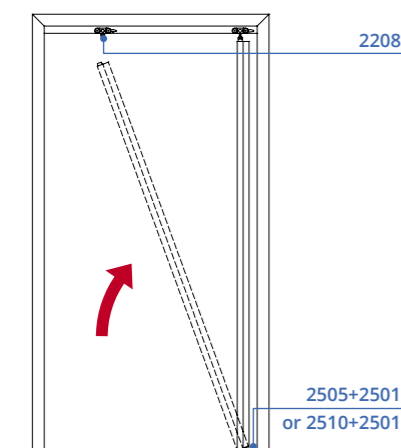

Montaggio della porta
Inserire la porta nel cardine inferiore fissato al pavimento, poi raddrizzarla innestando la staffa cardine superiore nella bussola sulla porta. Agganciare il perno del carrello alla staffa e registrare l'altezza.

Door mounting
Insert the door to the lower pivot fixed on floor, and straight it hooking the upper pivot bracket at the bush on the door. Joint the truck pin to the bracket and adjust the height.

Art. 2503 | Art. 2503

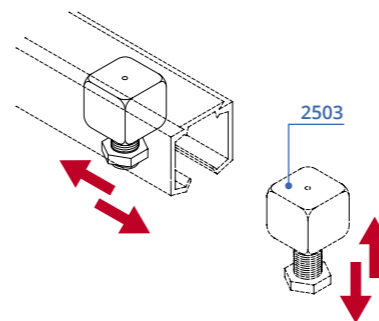

art. 2503
Inserimento nel binario del fermo di chiusura con molla e sfera di ritegno.

art. 2503
Inserting on rail of closing stopper with ball and restraint spring.

Varianti e optional | Variants and optionals

Art. 2200-2500 Staffa con funzione di auto-allineamento | Art. 2200-2500 Self aligning bracket

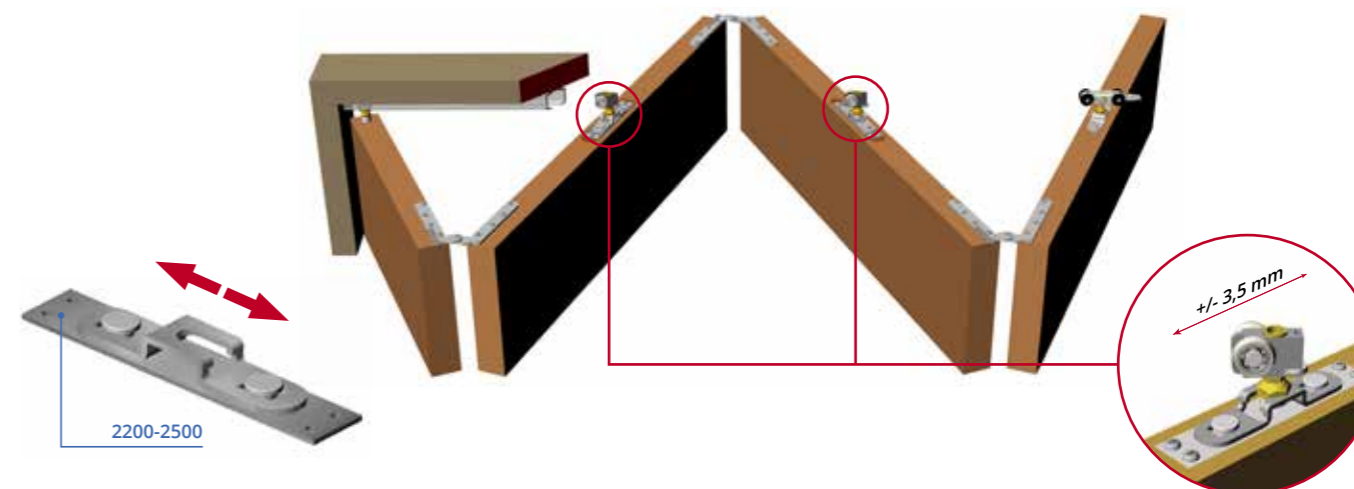

Art. 2510 Opzionale | Art. 2510 Optional

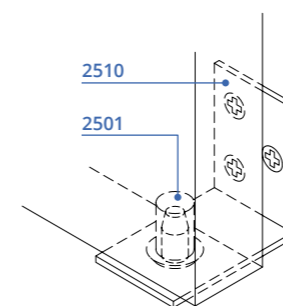

art. 2510 OPZIONALE
Cardini inferiori per fissaggio laterale sullo stipite, da utilizzare in sostituzione dell'art. 2505.

art. 2510 OPTIONAL
Lower pivot with lateral fixing, to use instead of art. 2505.

Serie 2500

Cerniere invisibili | Invisible hinges

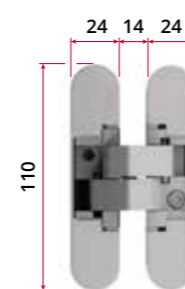

art. 1505
Cerniera invisibile in acciaio
Invisible steel hinge

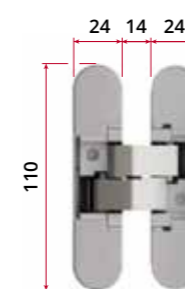

art. 1506
Cerniera invisibile in acciaio
Invisible steel hinge

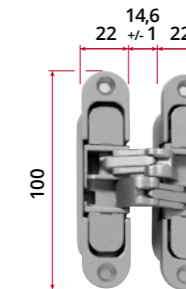

art. 1529
Cerniera invisibile in acciaio
Invisible steel hinge

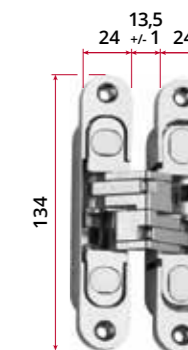

art. 1530
Cerniera invisibile in acciaio
Invisible steel hinge

Kit art. 2500/3100 A | Kit art. 2500/3100 A

Porta pieghevole con 3 pannelli a larghezza variabile.
Portata totale: 100 kg.

Folding door with 3 panels of varying width.
Total capacity: 100 kg

A

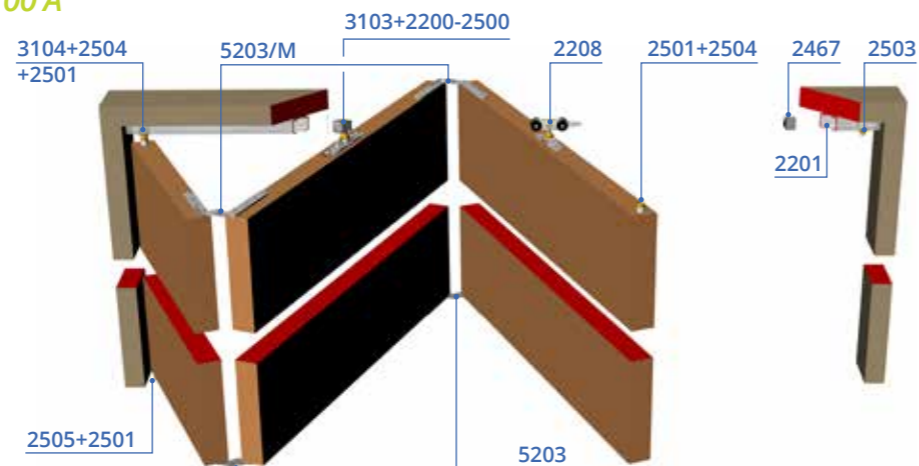

spessore anta door thickness	A	B	C per/for art. 2503
22 mm	5 mm	5 mm	Max 28 mm
30 mm	6 mm		
35 mm	8 mm		
40 mm	10 mm		
45 mm	12 mm		

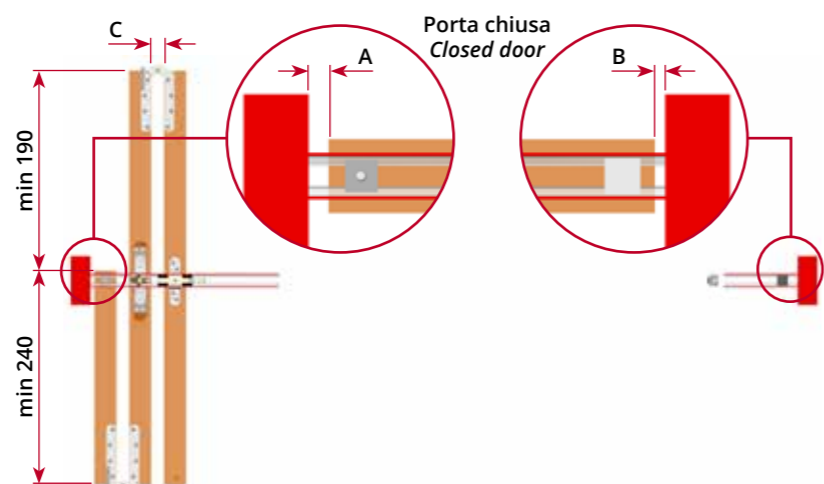

Kit compatibili
Matching kits



2500/3100/A

Kit art. 2500/3100 B | Kit art. 2500/3100 B

Porta pieghevole con 4 pannelli a larghezza variabile.
Portata totale: 100 kg.

Folding door with 4 panels of varying width.
Total capacity: 100 kg

B

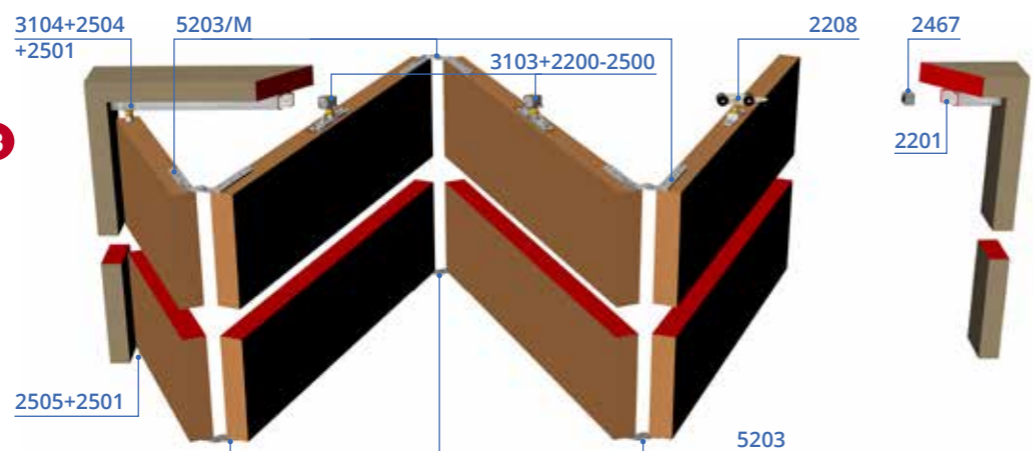

spessore anta door thickness	A	B	C per/for art. 2503
22 mm	5 mm	5 mm	Max 28 mm
30 mm	6 mm		
35 mm	8 mm		
40 mm	10 mm		
45 mm	12 mm		

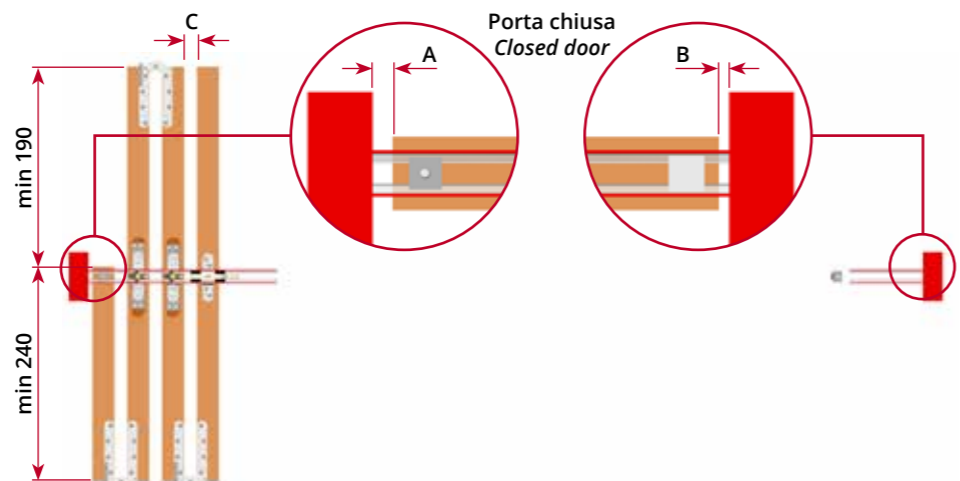

Kit compatibili
Matching kits



2500/3100/B

Lista Kit e profili principali | Kits list and main profiles



2530

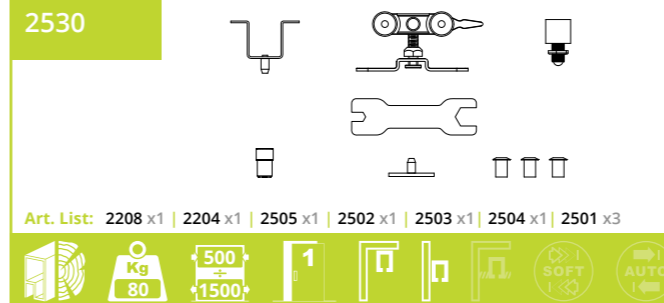

Art. List: 2208 x1 | 2204 x1 | 2505 x1 | 2502 x1 | 2503 x1 | 2504 x1 | 2501 x3



2560

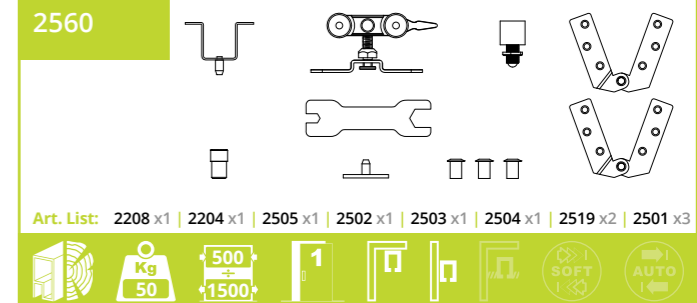

Art. List: 2208 x1 | 2204 x1 | 2505 x1 | 2502 x1 | 2503 x1 | 2504 x1 | 2519 x2 | 2501 x3



2570

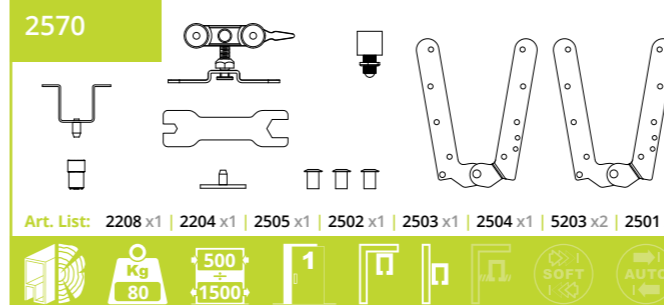

Art. List: 2208 x1 | 2204 x1 | 2505 x1 | 2502 x1 | 2503 x1 | 2504 x1 | 5203 x2 | 2501 x3



2580

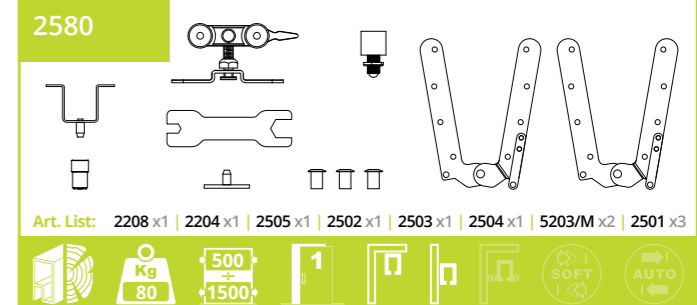

Art. List: 2208 x1 | 2204 x1 | 2505 x1 | 2502 x1 | 2503 x1 | 2504 x1 | 5203/M x2 | 2501 x3



2500/3100/A

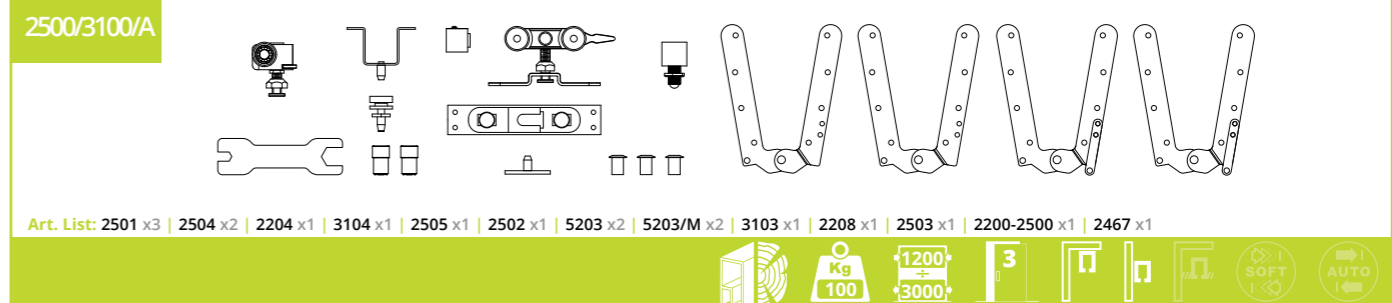

Art. List: 2501 x3 | 2504 x2 | 2204 x1 | 3104 x1 | 2505 x1 | 2502 x1 | 5203 x2 | 5203/M x2 | 3103 x1 | 2208 x1 | 2503 x1 | 2200-2500 x1 | 2467 x1



2500/3100/B

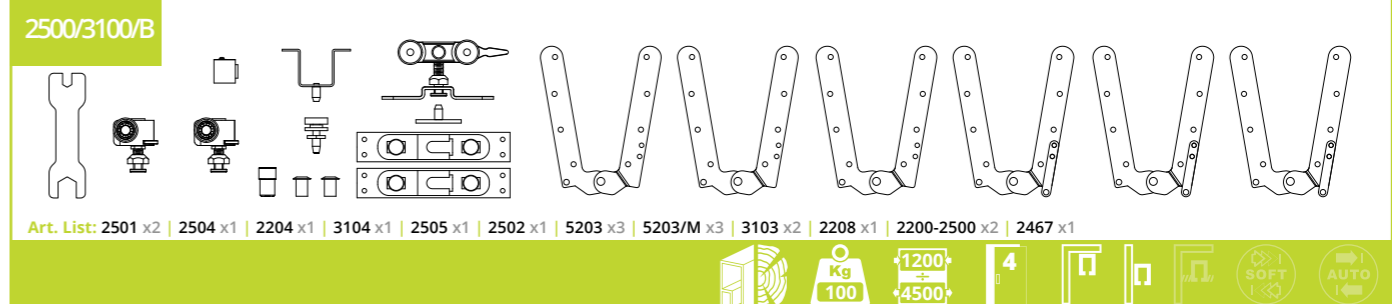

Art. List: 2501 x2 | 2504 x1 | 2204 x1 | 3104 x1 | 2505 x1 | 2502 x1 | 5203 x3 | 5203/M x3 | 3103 x2 | 2208 x1 | 2200-2500 x2 | 2467 x1



Serie 2500