

# Serie 3300

 Link to **Serie 2800**

**Mobile  
Furniture**

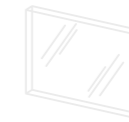

Sistema scorrevole monobinario per ante interne sospese

*One-rail sliding system for hanging internal doors*

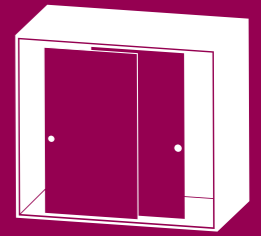

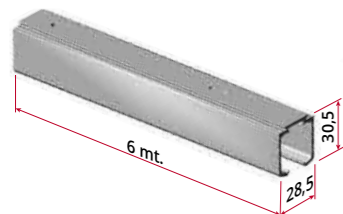

art. 2201  
Binario in alluminio  
Aluminium rail

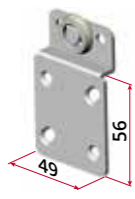

art. 3301  
Carrello superiore interno,  
con 1 cuscinetto a sfere  
Internal upper truck with 1  
roller bearing

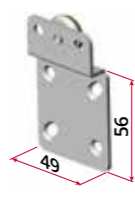

art. 3302  
Carrello superiore esterno,  
con 1 cuscinetto a sfere  
External upper truck with 1  
roller bearing

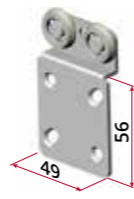

art. 3311  
Carrello superiore interno,  
con 2 cuscinetti a sfere  
Internal upper truck with 2  
roller bearing

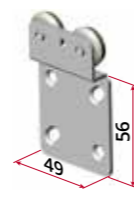

art. 3322  
Carrello superiore esterno,  
con 2 cuscinetti a sfere  
External upper truck with 2  
roller bearing

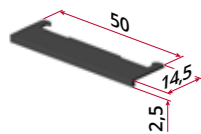

art. 3303  
Piastrina anticarrucolamento  
in nylon  
Nylon anti-fleeting device

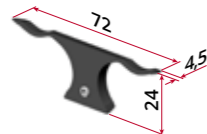

art. 3307  
per/for art. 2201  
Fermo in nylon  
Nylon stopper



art. 2805  
Pattino guida  
inferiore in nylon  
Nylon slider pin

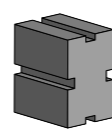

art. 220  
per/for art. 2201  
Spugna pulisci binario  
Cleaner rails sponge



art. 3308  
Chiave a brugola MM2  
Allen key MM2

## Informazioni tecniche | Technical informations

### Foratura delle ante | Doors perforation

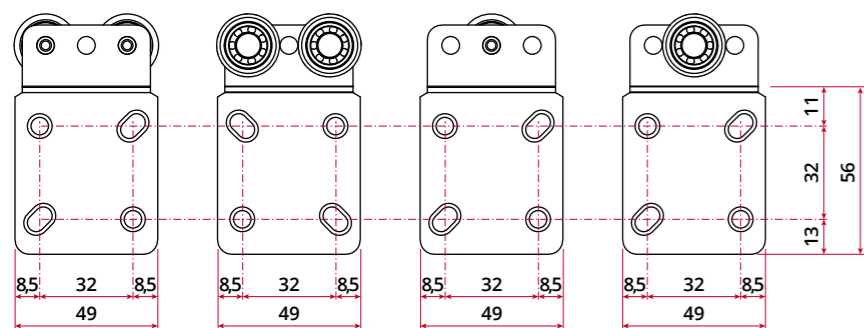
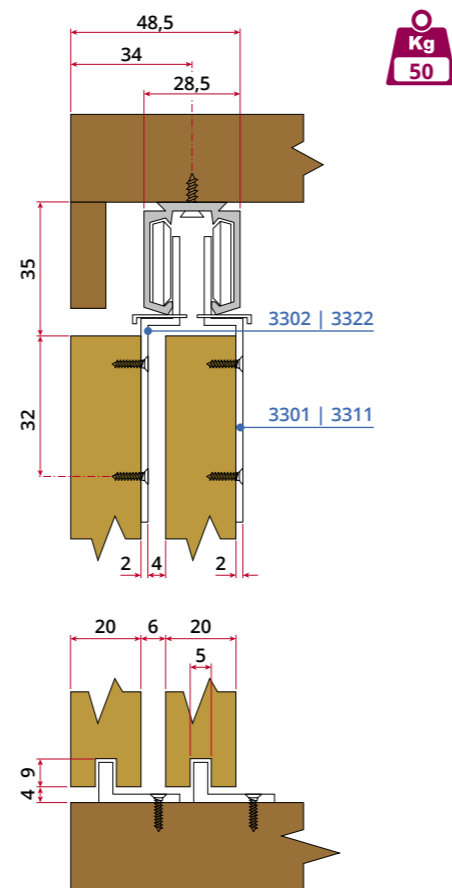
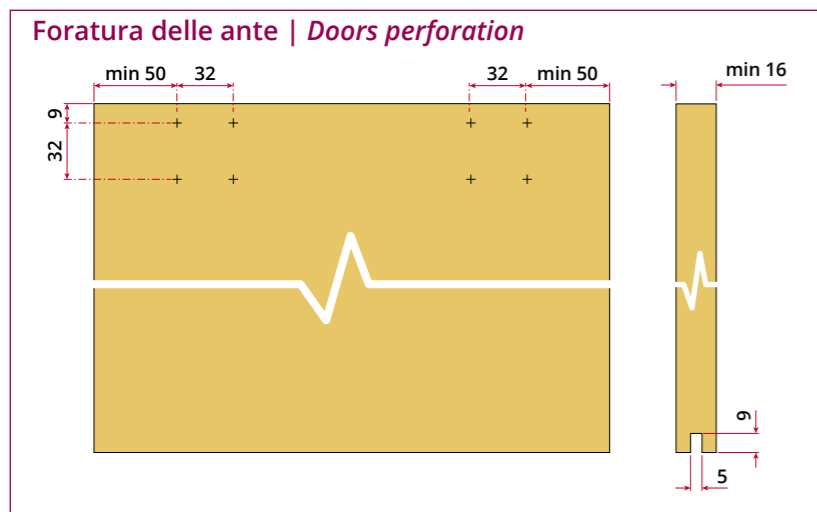

## Istruzioni montaggio | Assembly instructions

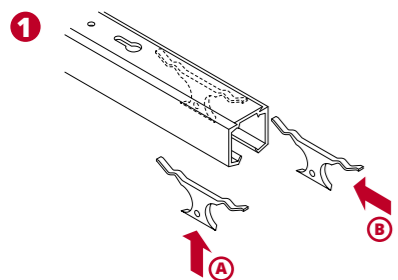

**1** Inserire i fermi di finecorsa. E' possibile fare questa operazione sia dal basso (A) che dalle estremità del binario (B)  
Insert the limit switch stoppers. This operation can be done both from the bottom (A) or from the end of the rail (B)

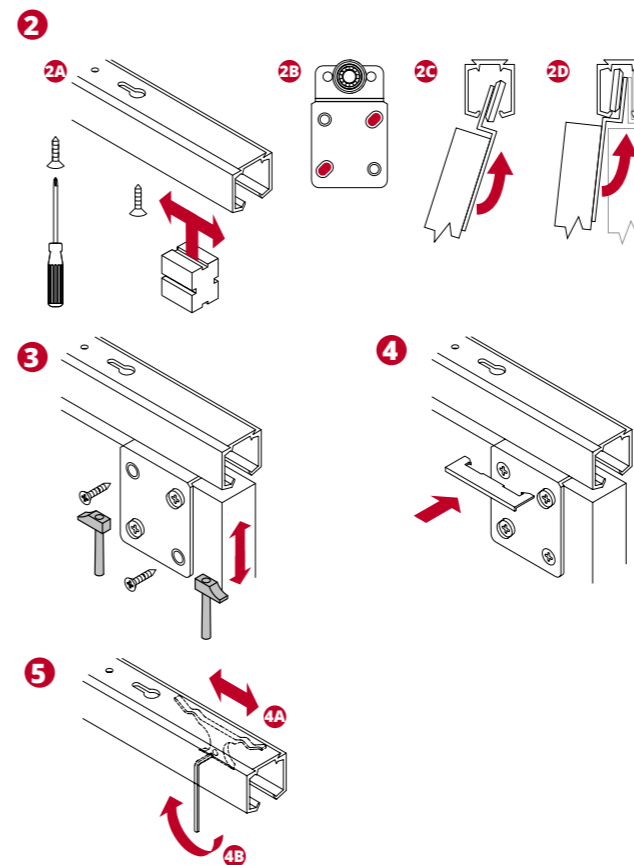

**2A** Fissare il binario con le viti e pulire con art 220  
Fix the rail with the screws and clean by art 220

**2B** Fissare i carrelli con le sole viti nelle asole  
Fix the carriages with the screws only in the slots

**2C** Inserire l'anta interna | Insert the inner door

**2D** Inserire l'anta esterna e fissare la guida inferiore esterna  
Insert the outer door and fix the lower external guide

**2E** Fissare le guide inferiori art 2805, fissando prima l'anta esterna e poi quella interna  
Fix the lower guides art 2805, first fixing the outer door and then the internal one

**3** Regolare i carrelli e fissarli con le 2 viti rimanenti  
Adjust the carriages and fix them with the 2 screws

**4** Installare la piastrina anti-scarrucolamento in nylon  
Install the nylon anti-fleeting device

**5** Fissare il fermo al binario con l'apposita chiave a brugola (art 3308) nella posizione corretta di fine corsa  
Fix the stopper to the rail in the correct position, with the appropriate hex-key (art 3308)

## Lista Kit e profili principali | Kits list and main profiles



**3320**

Art. List: 3302 x2 | 3303 x2 | 2805 x1

Icons: Kg 35, 350+1500, 1, SOFT, AUTO

**3310**

Art. List: 3301 x2 | 3303 x2 | 2805 x1

Icons: Kg 35, 350+1500, 1, SOFT, AUTO

**3380**

Art. List: 3302 x2 | 3303 x2 | 3307 x2 | 2805 x1 | 3308 x1

Icons: Kg 35, 350+1500, 1, SOFT, AUTO

**3370**

Art. List: 3301 x2 | 3303 x2 | 3307 x2 | 2805 x1 | 3308 x1

Icons: Kg 35, 350+1500, 1, SOFT, AUTO

**3382**

Art. List: 3322 x2 | 3303 x2 | 3307 x2 | 2805 x1 | 3308 x1

Icons: Kg 50, 350+1500, 1, SOFT, AUTO

**3372**

Art. List: 3311 x2 | 3303 x2 | 3307 x2 | 2805 x1 | 3308 x1

Icons: Kg 50, 350+1500, 1, SOFT, AUTO

