

Serie 5700

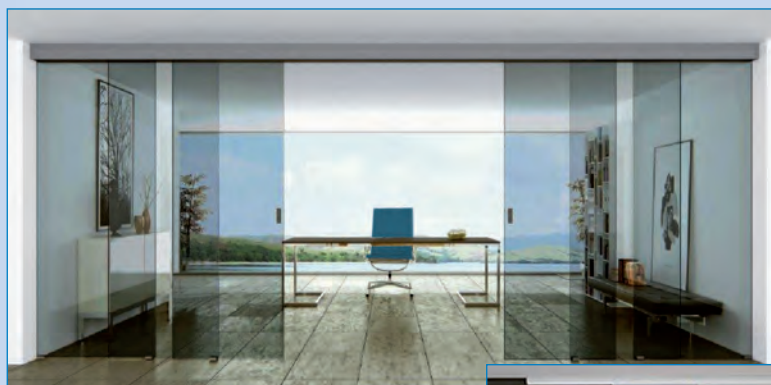

Sistema telescopico sincronizzato
adatto a 2 porte scorrevoli più
eventuale pannello fisso.

Synchronized telescopic system
suitable for 2 sliding doors plus
a possible fixed panel.



MADE IN ITALY
Villes 2000

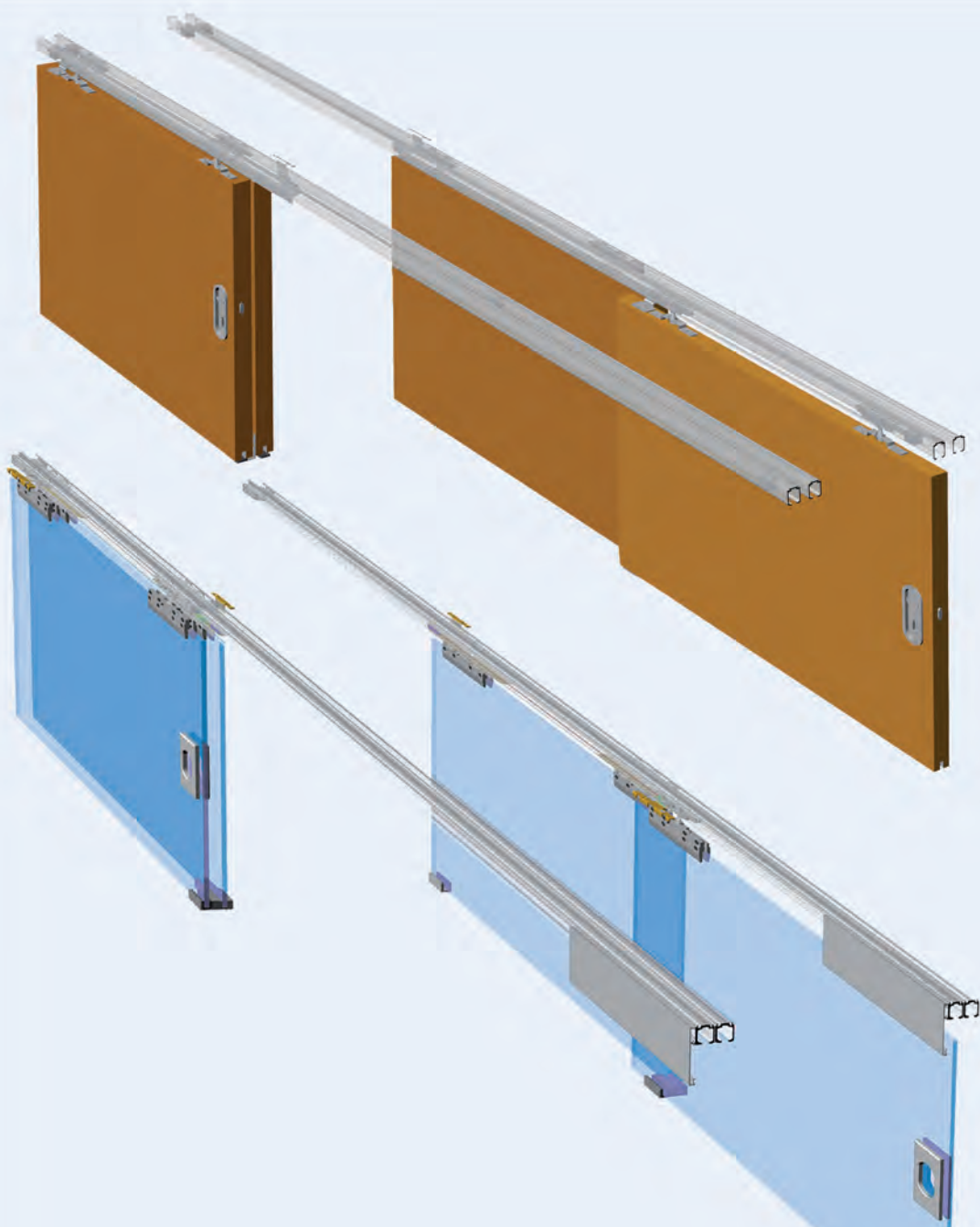



LARGHEZZA ANTE/DOORS WIDTH : Min.470 mm. (540 mm. con/with soft close) - max 2000 mm.

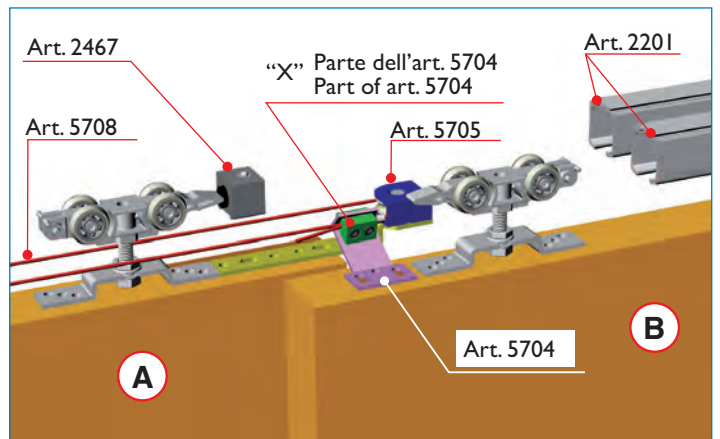
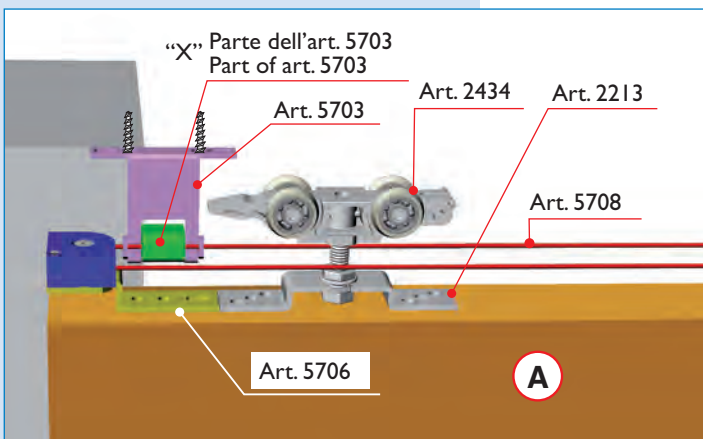
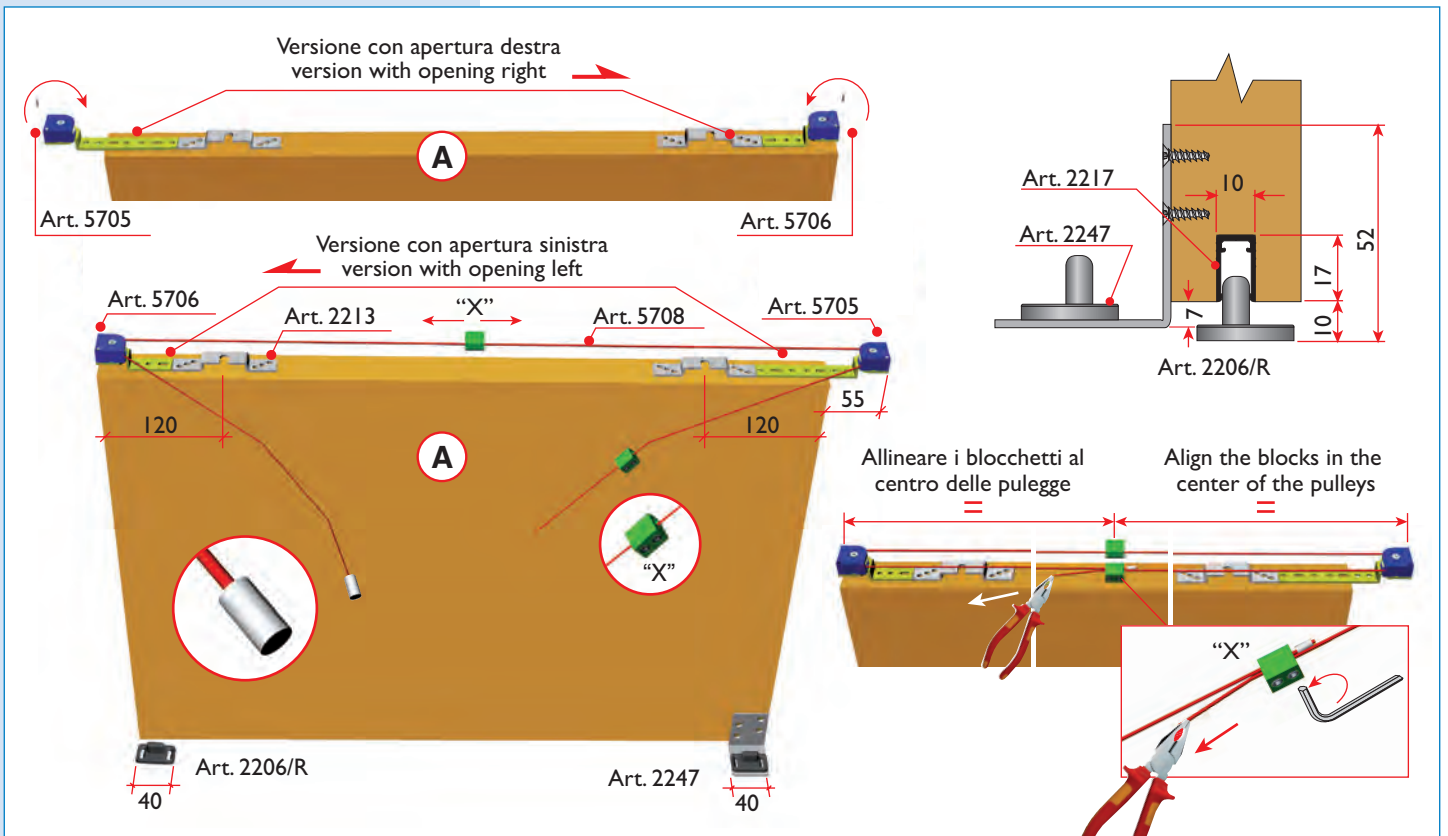
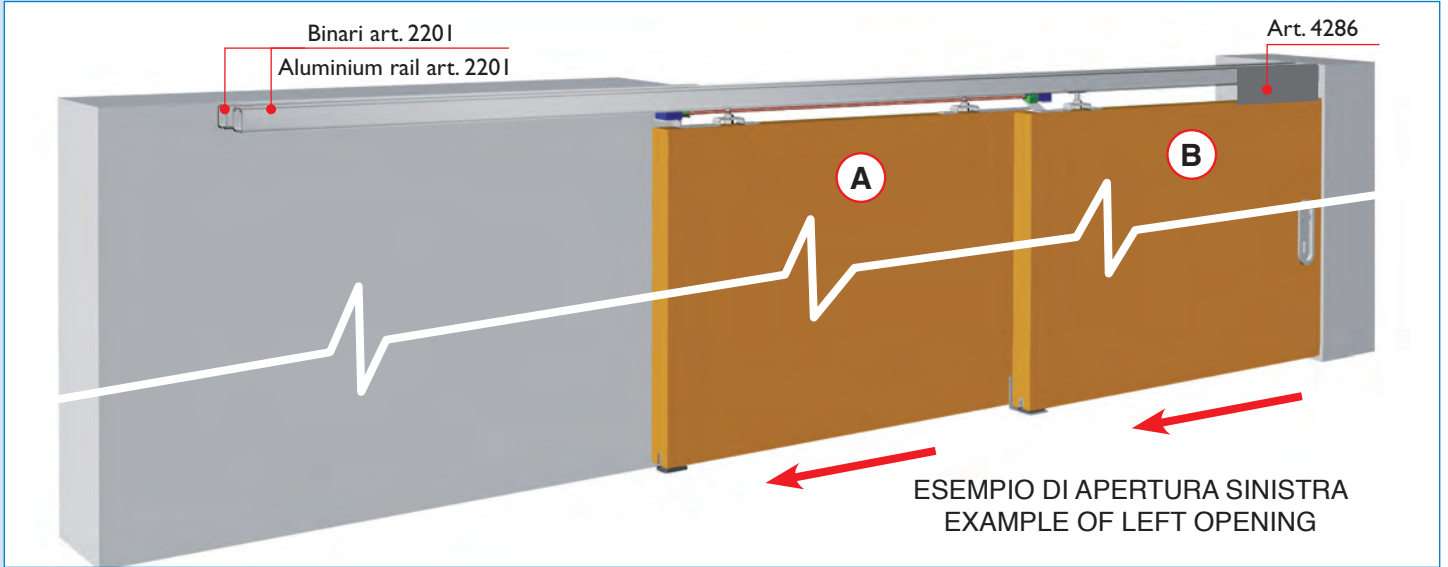

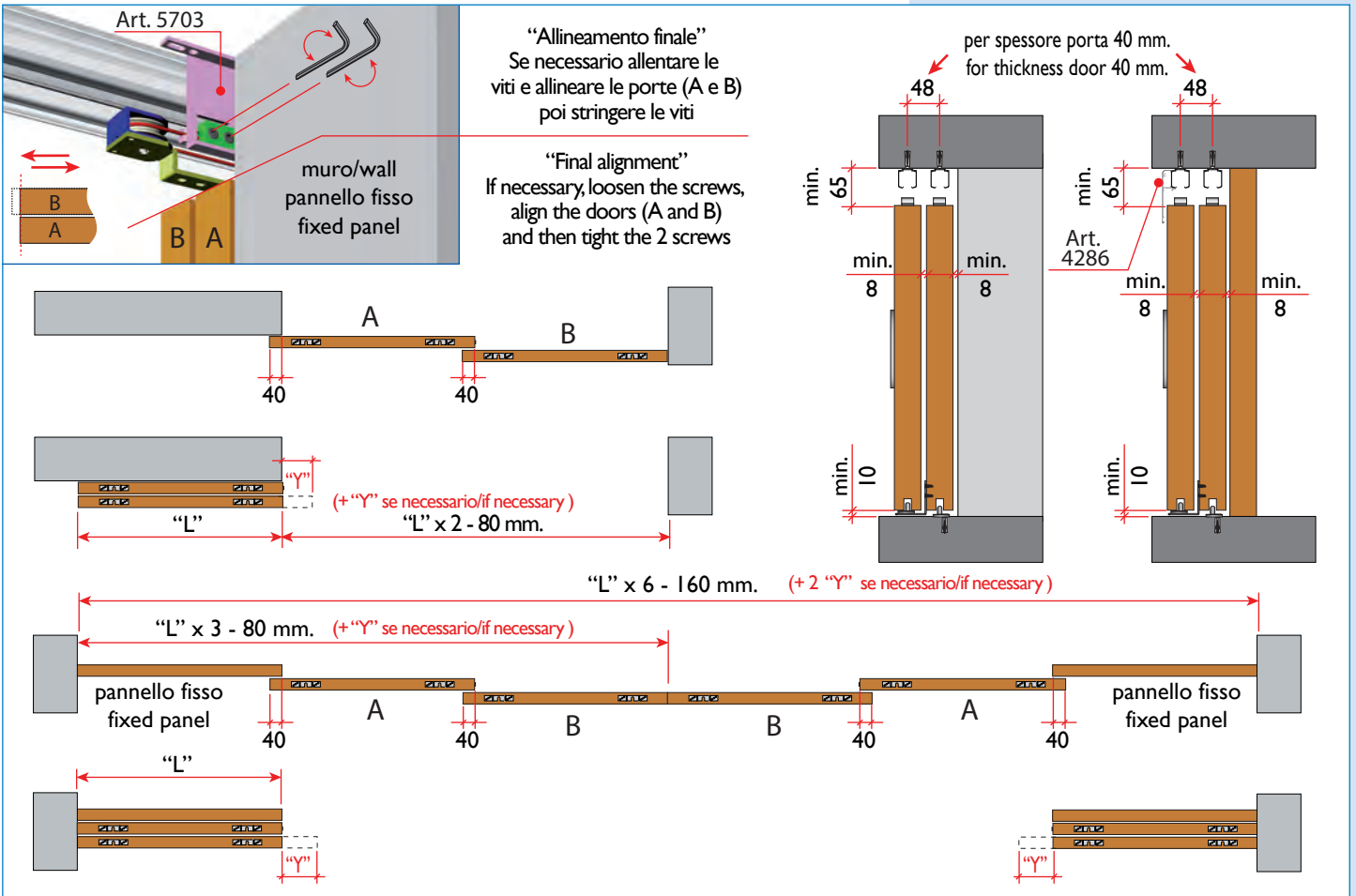
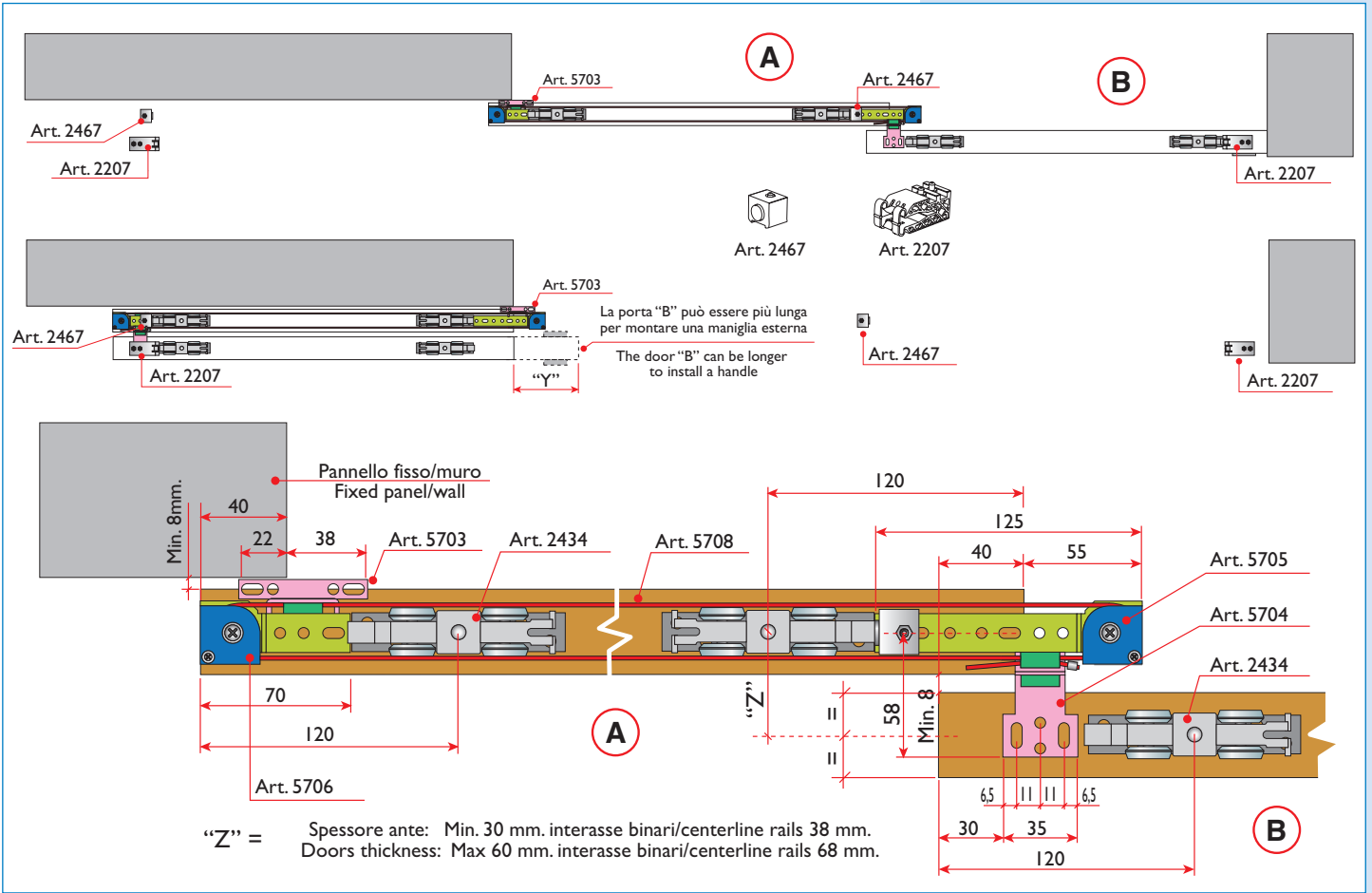



LARGHEZZA ANTE/DOORS WIDTH : Min.470 mm. (540 mm. con/with soft close) - max 2000 mm.

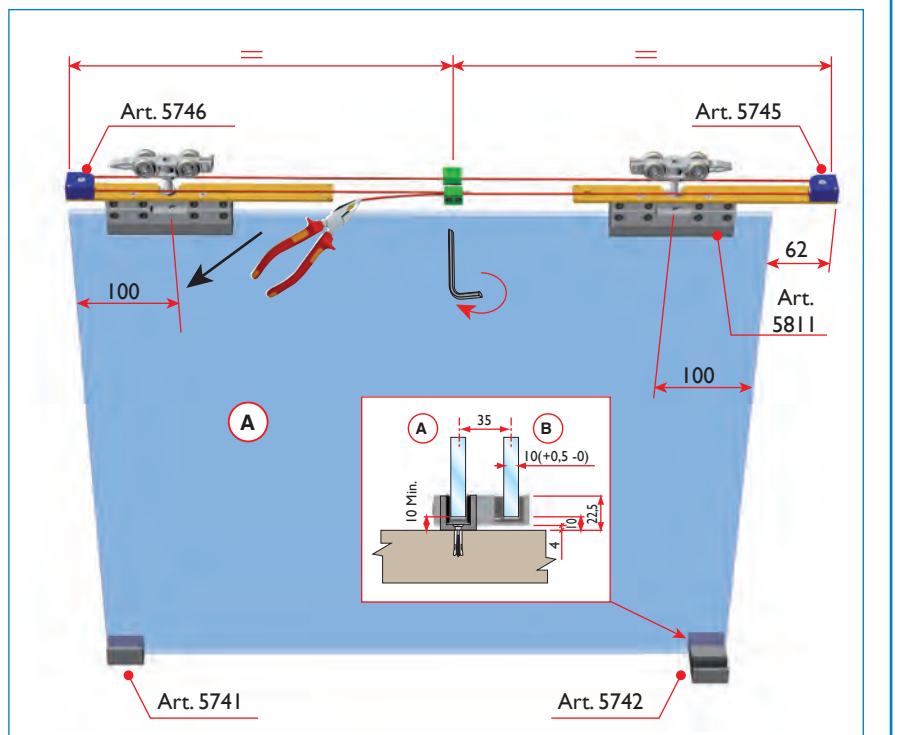
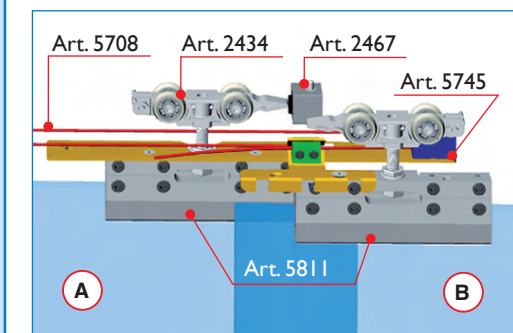
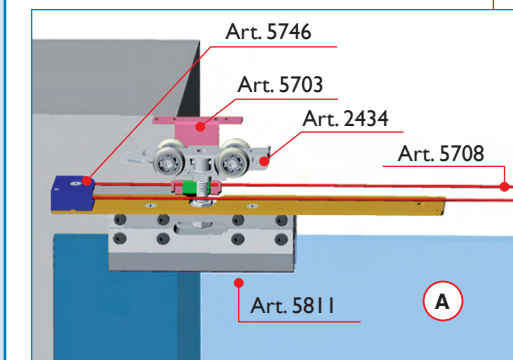
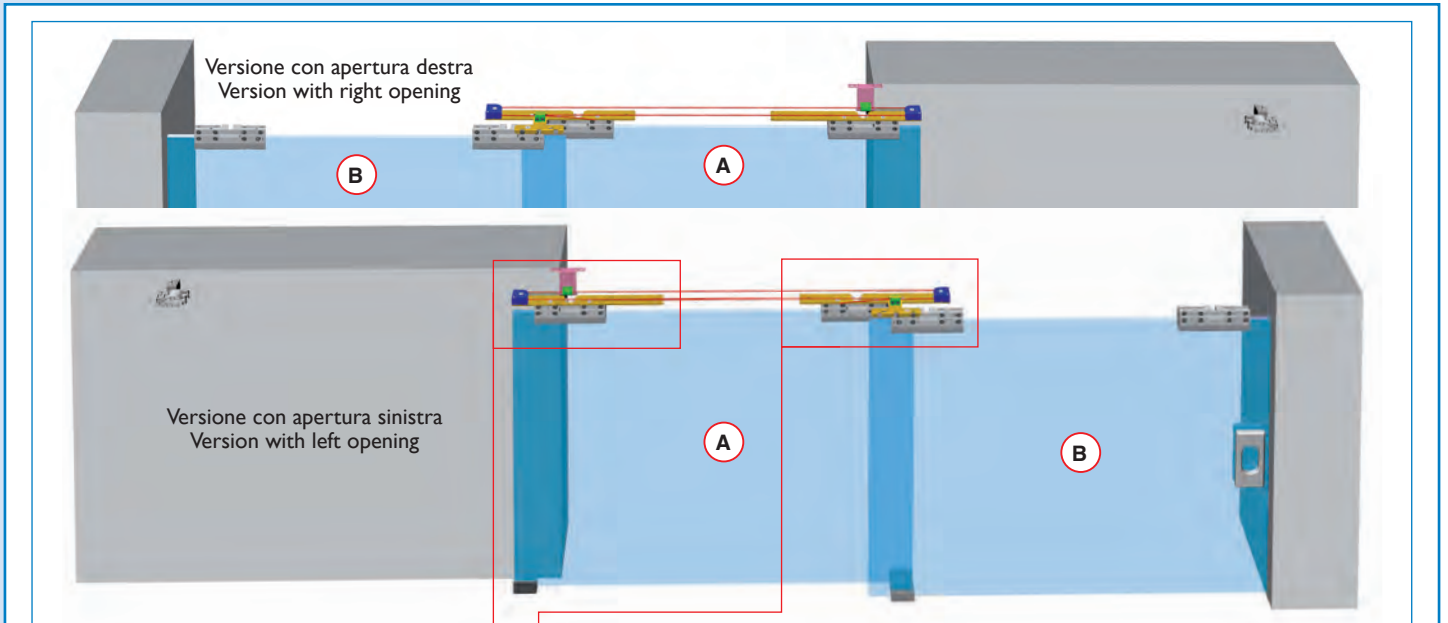
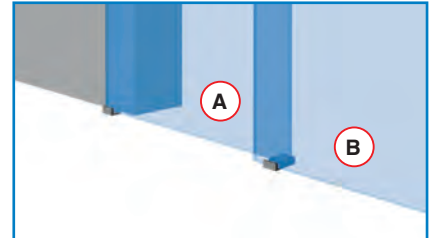
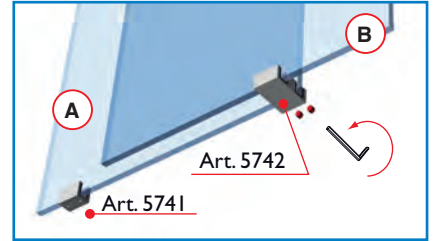
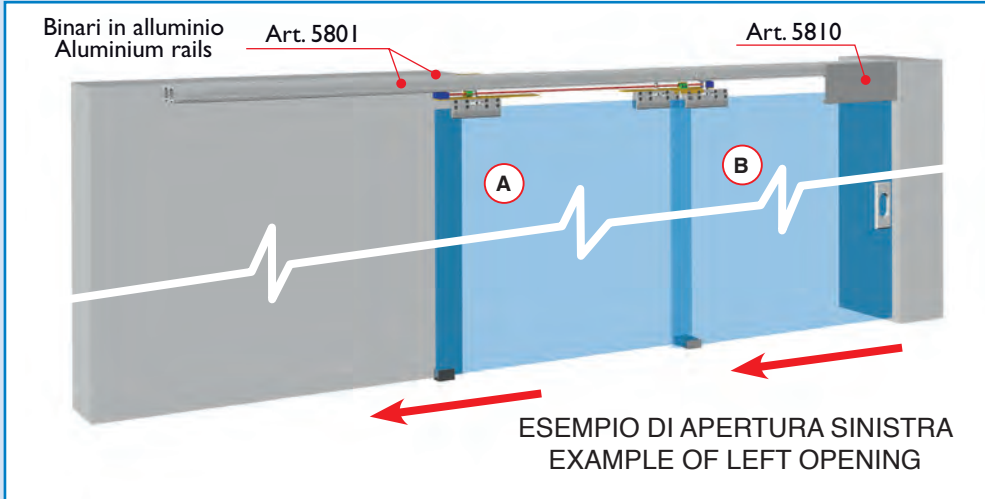

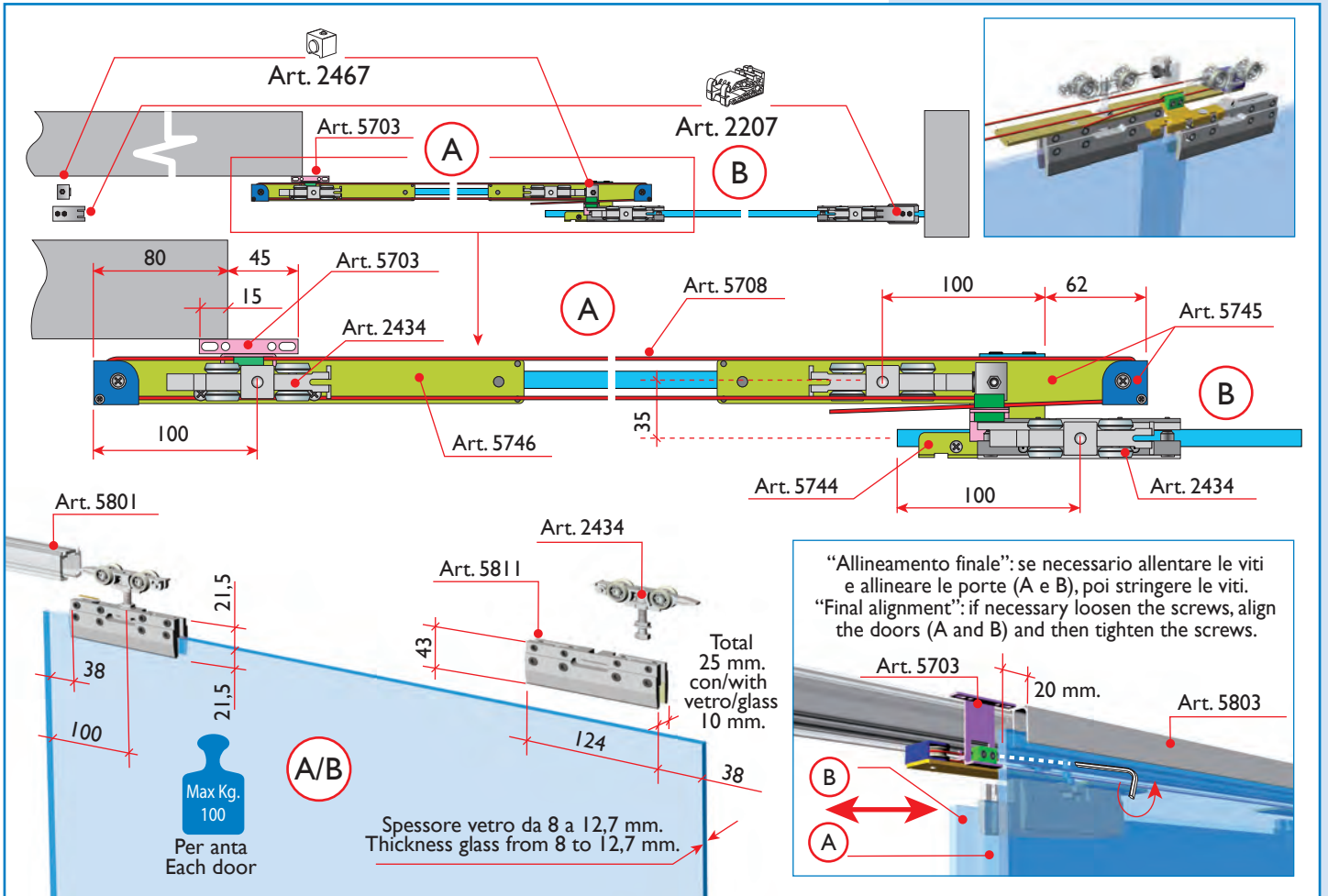
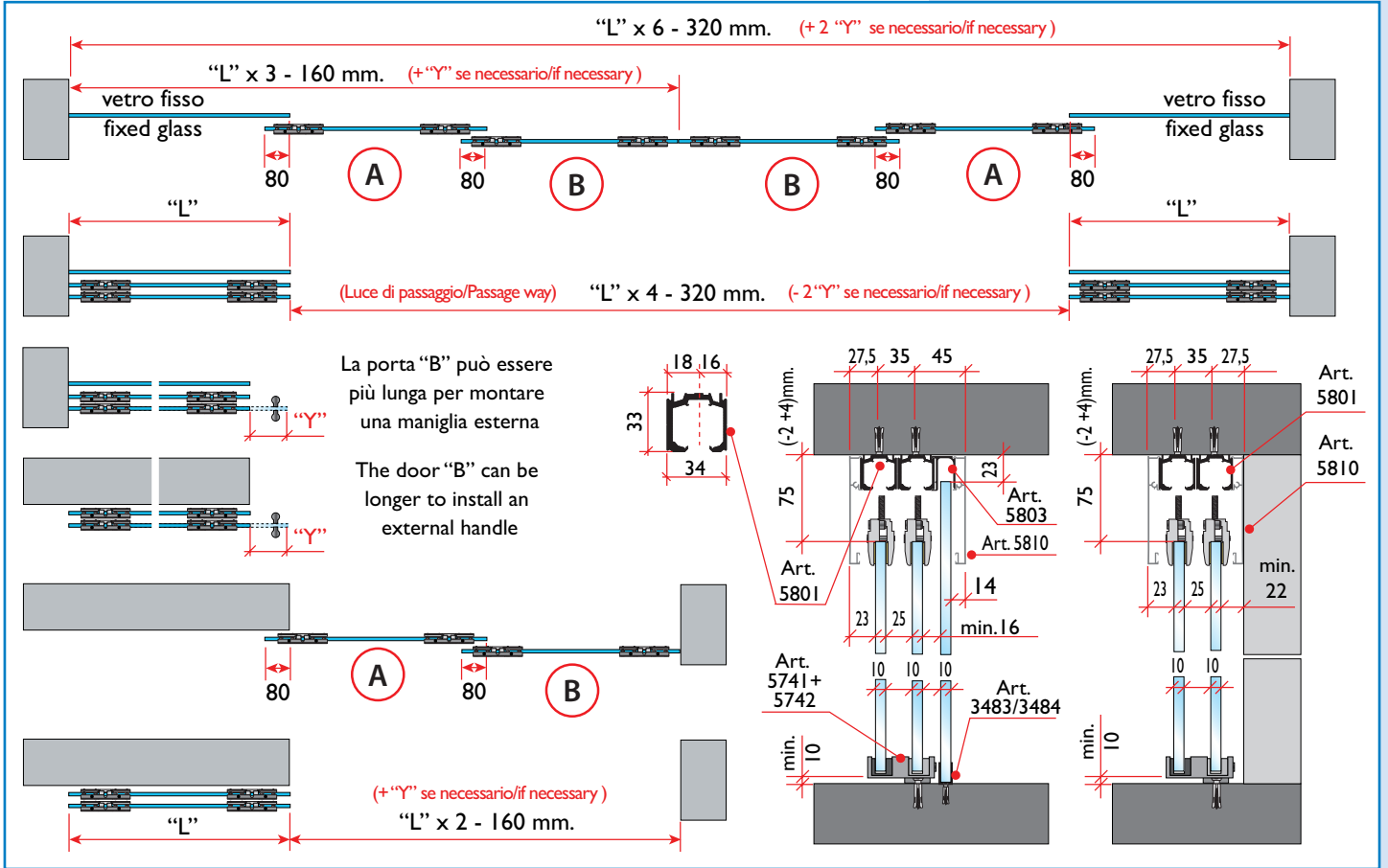



SEZIONI / SECTIONS

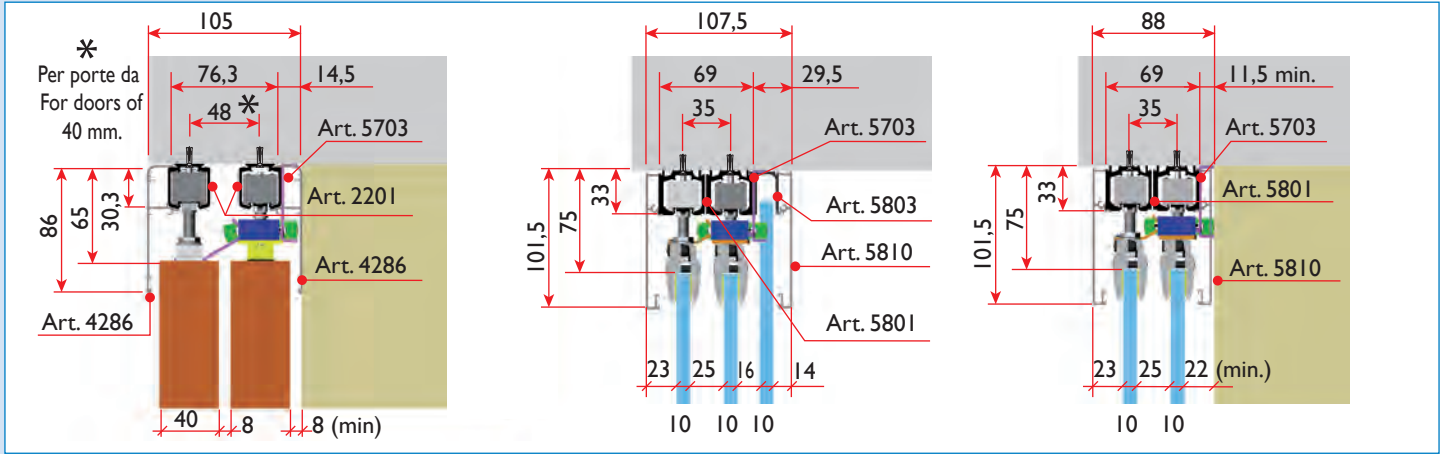

ISTRUZIONI / INSTRUCTIONS

