

DESIGN MARIANDESIGN MARIANDESIGN
MARIANDESIGN MARIANDESIGN MARIANDESIGN
MARIANDESIGN MARIANDESIGN MARIANDESIGN
DESIGN MARIANDESIGN MARIANDESIGN MARIANDESIGN

MADE IN ITALY

DESIGN MARIANDESIGN MARIANDESIGN MARIANDESIGN
MARIANDESIGN MARIANDESIGN MARIANDESIGN MARIANDESIGN
DESIGN MARIANDESIGN MARIANDESIGN MARIANDESIGN
MARIANDESIGN MARIANDESIGN MARIANDESIGN MARIANDESIGN
MARIANDESIGN MARIANDESIGN MARIANDESIGN MARIANDESIGN

mariani[®]

DESIGNERS

mariani®

Lucidi Pevere

Gianfranco Melegari

After Design

Simone Hybsch

Mauro Valsecchi

Mauro Ronchi

Fulvio Manenti



Designpreis
Deutschland
2010

NOMINEE

Il German Design Council (Rat für Formgebung) è stata fondata per iniziativa del Parlamento federale tedesco nel 1953 per rispondere al bisogno crescente del mondo delle imprese per informazioni sulla progettazione. Oggi, il German Design Council è uno dei centri di competenza leader nel mondo per la comunicazione e il know-how nel campo del design. Con i concorsi, mostre, conferenze, consulenze, ricerche e pubblicazioni, offrendo nuove prospettive per i rappresentanti delle imprese e delle discipline del design.

The German Design Council (Rat für Formgebung) was founded as an initiative of the German Federal Parliament in 1953 to meet the growing need of the business world for information about design. Today, the German Design Council is one of the world's leading competence centres for communication and know-how transfer in the design field. With competitions, exhibitions, conferences, consulting, research and publications, we offer new perspectives for representatives of business and design disciplines.



reddot design award
winner 2009

Red Dot Design Award

Con più di 11.000 partecipazioni provenienti da 61 Paesi il premio internazionale "Red Dot Design Award" è il più grande e più celebre concorso di progettazione in tutto il mondo.

Ogni anno una giuria internazionale valuta e vaglia i prodotti presentati in base a criteri quali il grado di innovazione, funzionalità e la qualità formale. Il premio è un sigillo di qualità riconosciuto a livello internazionale, è sinonimo di appartenenza al meglio nella progettazione e delle imprese. Tutti i prodotti premiati vengono inclusi ed esposti nel Red Dot Design Museum di Essen in Germania.

With over 11,000 participants from 61 different countries, the international "Red Dot Design Award" is the largest and most famous design contest in the world.

Each year, an international jury evaluates and judges the products presented on the basis of criteria such as level of innovation, functionality and formal quality. The Award is an internationally recognised mark of quality that gives the winner a sort of membership in an elite group of the best companies and the best designs.

All winning products are displayed in the Red Dot Design Museum in Essen, Germany.

DESIGNMARIANIDESIGNMARIANIDESIGN
MARIANIDESIGNMARIANIDESIGNMARIAN
MARIANIDESIGNMARIANIDESIGNMARIAN
DESIGNMARIANIDESIGNMARIANIDESIGN

REFERENCES

DESIGNMARIANIDESIGNMARIANIDESIGN
MARIANIDESIGNMARIANIDESIGNMARIAN
DESIGNMARIANIDESIGNMARIANIDESIGN
MARIANIDESIGNMARIANIDESIGNMARIAN
DESIGNMARIANIDESIGNMARIANIDESIGN

WTC

Bahrain

KEMPINSKI SIAM HOTEL

Bangkok

THE VENETIAN

Las Vegas

CARBONELL

Miami

RIVERSIDE BUILDINGS

New York City

MYSTIC CENTER

Boston

ROWAN LOFTS

Los Angeles

5TH AVENUE CONDOS

Austin

BEACON COUT

New York City

RESIDENTIAL COMPLEX OF 264 VILLAS

Abu Dhabi

RESIDENTIAL COMPLEX OF 28 VILLAS

Abu Dhabi

PETROVSKIY PUTEVOY DVOREZ

Mosca



ALIAS pag. 14



HORIZON pag. 15



ICE pag. 16



ICE 2 pag. 17



ICE 4 LEATHER pag. 18



ICE 5 RUB pag. 19



ICE 5 NIGHT SHOT pag. 20



ICE 6 SW pag. 21



SCAN pag. 22



SINUA pag. 23



SOUND pag. 24



ARTE pag. 28



CLOUD pag. 29



CLOUD 2 RUB pag. 30



CLOUD 2 NIGHT SHOT pag. 31



CLOUD 3 LEATHER pag. 32



CLOUD 4 SW pag. 33



COMET pag. 34



FUTURA pag. 35



OVER pag. 36



RIVA pag. 37



SARA pag. 38



SOFT pag. 39



SUN pag. 40



SUN 2 pag. 41



SUN 3 pag. 42



SUN 4 SW pag. 43



ZENITH pag. 44



ADRIANA pag. 50



ASIA pag. 51



BONN pag. 52



DARIA pag. 53



DIANA pag. 54



EGLE pag. 55



GOCCIA pag. 56



GOLF pag. 57



JENNY pag. 58



JULIA pag. 59



LAGUNA pag. 60



LISA pag. 61



LORELLA pag. 62



LOTUS pag. 63



MARA pag. 64



MAREA pag. 65



MARIELLA pag. 66



OLIMPO pag. 67



ONDA pag. 68



PETRA pag. 69



SHADOW pag. 70



SILVIA pag. 71



SOGNO pag. 72



STYLO pag. 73



VELA pag. 74



VENTO pag. 75



VENUS pag. 76



ZOE pag. 77



ALICE pag. 84



CRYSTAL pag. 85



EMILY pag. 86



FIONA pag. 87



FIRENZE EBANO pag. 88



GOCCIA pag. 89



LINEA pag. 90



LINZ pag. 91



ROMA pag. 92



SHADOW pag. 93



SIENNA EBANO pag. 94



STYLO pag. 95



VENTO pag. 96



ALBIOS pag. 104



DRACO pag. 105



MEGRES pag. 106

**MANIGLIONI
PULL HANDLES**

**MEGRES
MANIGLIONE**
pag. 107



EGLE
pag. 112



**ITALY
LEATHER**
pag. 113



ITALY
pag. 114



**ITALY
CURVO**
pag. 115



**ITALY
ESSE**
pag. 116



KIRA
pag. 117



ONDA
pag. 118



ORIENT
pag. 119



QBE
pag. 120



SMERALDO
pag. 121



**SMERALDO
TORCILIONE**
pag. 122



TOPAZIO
pag. 123



**TOPAZIO
TORCILIONE**
pag. 124



VENUS
pag. 125



ZANTE
pag. 126



POMOLI-KNOBS
pag. 130



**BUCALETTERE
LETTER PLATES**
pag. 138



**PLACCHE INCASSO
FLUSH PLATES**
pag. 142



**BOCCHETTE WC
TURN AND RELEASES**
pag. 148



**BOCCHETTE
KEY HOLES**
pag. 152



ROSETTE-ROSES
pag. 156



PLACCHE-PLATES
pag. 160



**ARTICOLI VARI
VARIOUS ARTICLES**
pag. 164

MANIGLIE-LEVERS

ADRIANA	pag. 50	LINZ	pag. 91
ALBIOS	pag. 104	LISA	pag. 61
ALIAS	pag. 14	LORELLA	pag. 62
ALICE	pag. 84	LOTUS	pag. 63
ARTE	pag. 28	MARA	pag. 64
ASIA	pag. 51	MAREA	pag. 65
BONN	pag. 52	MARIELLA	pag. 66
CLOUD	pag. 29	MEGRES	pag. 106
CLOUD 2 RUB	pag. 30	OLIMPO	pag. 67
CLOUD 2 NIGHT SHOT	pag. 31	ONDA	pag. 68
CLOUD 3 LEATHER	pag. 32	OVER	pag. 36
CLOUD 4 SW	pag. 33	PETRA	pag. 69
COMET	pag. 34	RIVA	pag. 37
CRYSTAL	pag. 85	ROMA	pag. 92
DARIA	pag. 53	SARA	pag. 38
DIANA	pag. 54	SCAN	pag. 22
DRACO	pag. 105	SHADOW	pag. 70
EGLE	pag. 55	SHADOW	pag. 93
EMILY	pag. 86	SIENA EBANO	pag. 94
FIONA	pag. 87	SILVIA	pag. 71
FIRENZE EBANO	pag. 88	SINUA	pag. 23
FUTURA	pag. 35	SOFT	pag. 39
GOCCIA	pag. 56	SOGNO	pag. 72
GOCCIA	pag. 89	SOUND	pag. 24
GOLF	pag. 57	STYLO	pag. 73
HORIZON	pag. 15	STYLO	pag. 95
ICE	pag. 16	SUN	pag. 40
ICE 2	pag. 17	SUN 2	pag. 41
ICE 4 LEATHER	pag. 18	SUN 3	pag. 42
ICE 5 RUB	pag. 19	SUN 4 SW	pag. 43
ICE 5 NIGHT SHOT	pag. 20	VELA	pag. 74
ICE 6 SW	pag. 21	VENTO	pag. 75
JENNY	pag. 58	VENTO	pag. 96
JULIA	pag. 59	VENUS	pag. 76
LAGUNA	pag. 60	ZENITH	pag. 44
LINEA	pag. 90	ZOE	pag. 77

MANIGLIONI-PULL HANDLES

EGLE	pag. 112
ITALY	pag. 114
ITALY CURVO	pag. 115
ITALY ESSE	pag. 116
ITALY LEATHER	pag. 113
KIRA	pag. 117
MEGRES	pag. 107
ONDA	pag. 118
ORIENT	pag. 119
QBE	pag. 120
SMERALDO	pag. 121
SMERALDO TORCILIONE	pag. 122
TOPAZIO	pag. 123
TOPAZIO TORCILIONE	pag. 124
VENUS	pag. 125
ZANTE	pag. 126

ACCESSORI-ACCESSORIES	pag. 168
ARTICOLI VARI-VARIOUS ARTICLES	pag. 164
BOCCHETTE WC-TURN AND RELEASES	pag. 148
BOCCHETTE-KEY HOLES	pag. 152
BUCALETTERE-LETTER PLATES	pag. 138
FINITURE-FINISHING	pag. 174
PLACCHE INCASSO-FLUSH PLATES	pag. 142
PLACCHE-PLATES	pag. 160
POMOLI-KNOBS	pag. 130
ROSETTE-ROSES	pag. 156
ESPOSITORI	pag. 176
PACKAGING	pag. 177



Linea Abe:
Combinazione ideale tra innovazione stilistica e soluzioni tecniche d'avanguardia.
Abe Line:
Ideal combination of stylistic innovation and trendy technical solution.



Linea Qbe:
Sintesi di design ed innovazione, perfetto equilibrio estetico adatto agli ambienti più raffinati ed evoluti.
Qbe Line:
Summari of design and innovation, a perfect aesthetic balance suitable for elegant and evolutionary setting.



Linea Dbe:
racchiude in sé una variegata proposta di stili, con lo scopo di soddisfare le diverse richieste nel design di interni.
Dbe Line:
Embodies a diverse style proposals. The aim is to satisfy the various requests for interior design.



Linea Historia:
Dalla scuola Bauhaus, nasce la linea maniglie Historia che riprende la stessa filosofia che aveva animato i progetti di questi architetti: semplicità, design, praticità.
Historia Line:
Born this line of handles is reproducing the same philosophy that had inspired the architects' drawings of the Bauhaus school.



Linea Ibe:
E' una linea dedicata e realizzata in Acciaio INOX.
Ibe Line:
Fully realized in Stainless Steel.

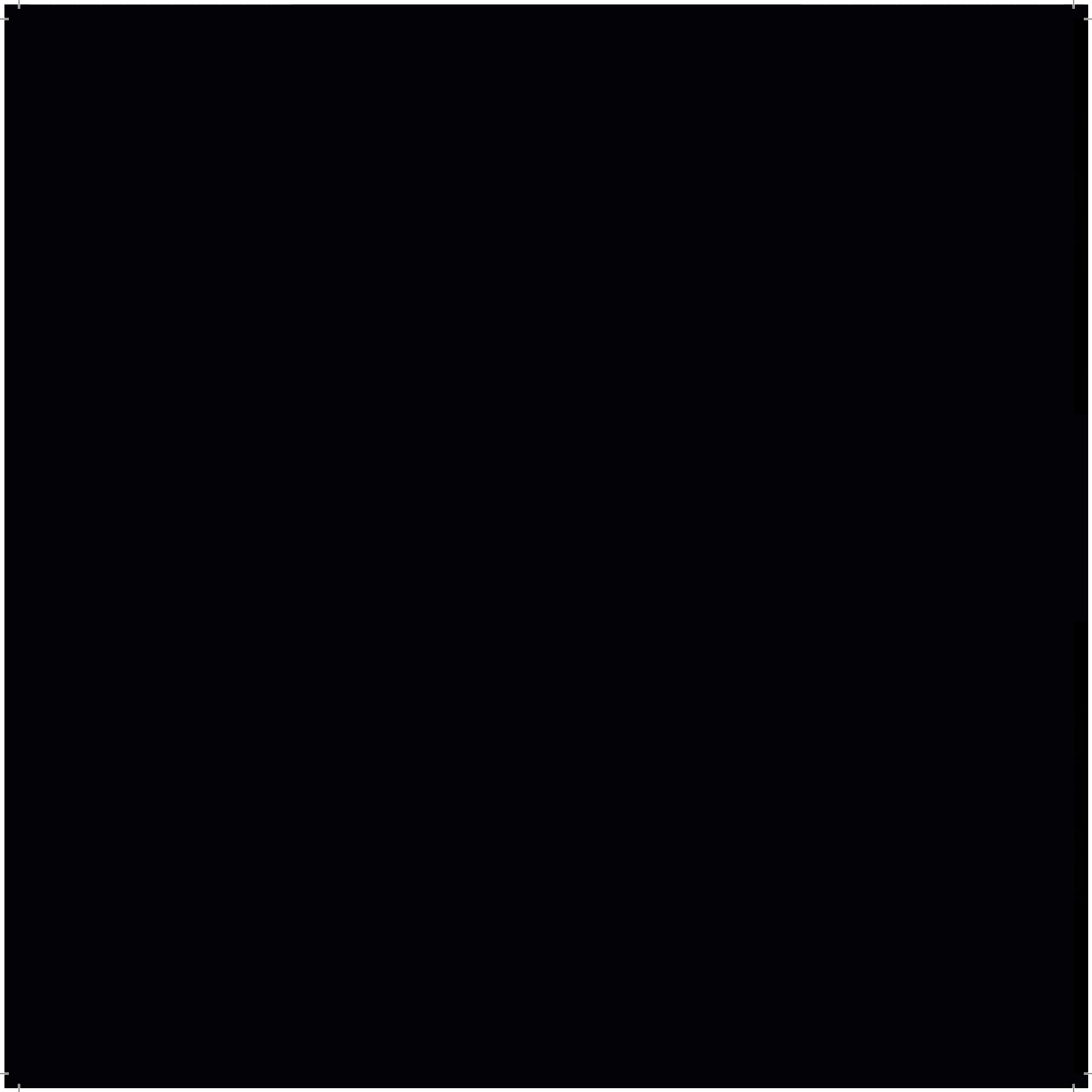

DESIGN MARIANIDESIGN MARIANIDESIGN
MARIANIDESIGN MARIANIDESIGN MARIAN
MARIANIDESIGN MARIANIDESIGN MARIANIDESIGN
DESIGN MARIANIDESIGN MARIANIDESIGN MARIAN

MANIGLIE

LEVERS



DESIGN MARIANIDESIGN MARIANIDESIGN MARIAN
MARIANIDESIGN MARIANIDESIGN MARIANIDESIGN
DESIGN MARIANIDESIGN MARIANIDESIGN MARIAN
MARIANIDESIGN MARIANIDESIGN MARIANIDESIGN
MARIANIDESIGN MARIANIDESIGN



mariani

ALIAS
design:
Gianfranco Melegari



CR

CS

Base Material:
Ottone/Alluminio
Solid Brass/Aluminium

Double Finishes

CRCS/CR

CSCR/CS

NSCR/NS

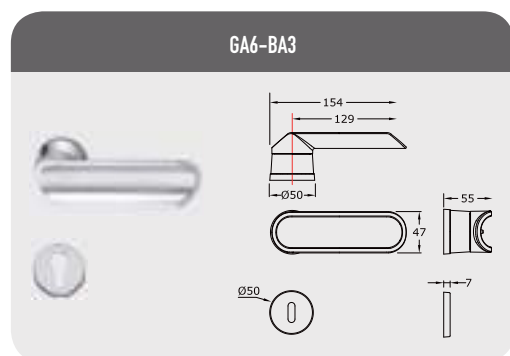

Maniglia con rosetta/bocchetta
Lever on rose and key hole

 n. 1 set



mariani[®]

HORIZON

design:
Gianfranco Melegari



CR

CS

Base Material:
Ottone/Alluminio
Solid Brass/Aluminium

Double Finishes

CRCS/CR

CSCR/CS

NSCR/NS

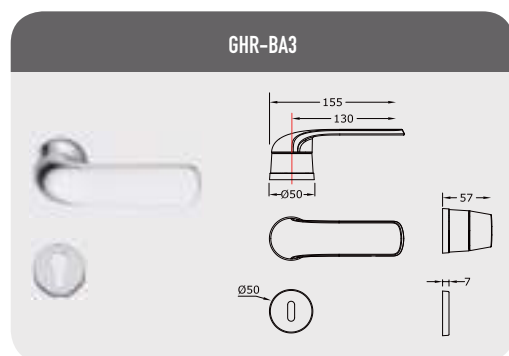

Maniglia con rosetta/bocchetta
Lever on rose and key hole

 n. 1 set



mariani

ICE

design: Studio Mariani



CR

CS

Base Material:
Ottone - Alluminio
Solid Brass - Aluminium

Double Finishes

CRCS/CR

CSCR/CS

NSCR/NS

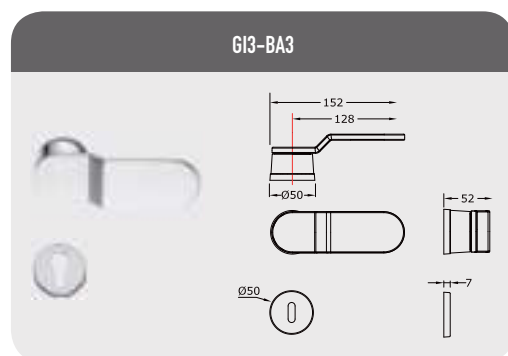

Maniglia con rosetta/bocchetta
Lever on rose and key hole

 n. 1 set



mariani

ICE 2
design: Studio Mariani



CR

CS

Base Material:
Ottone/Alluminio
Solid Brass/Aluminium

Double Finishes

CRCS/CR

CSCR/CS

NSCR/NS

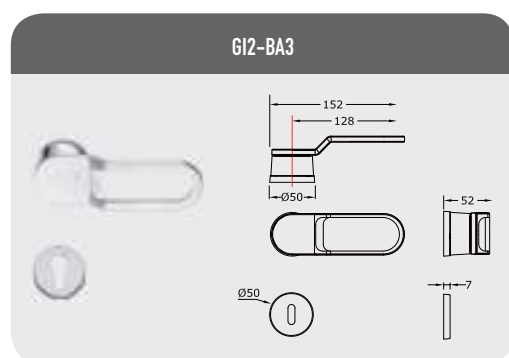

Maniglia con rosetta/bocchetta
Lever on rose and key hole

 n. 1 set



mariani

ICE 4 LEATHER
design: Studio Mariani



CR

CS

Base Material:
Ottone/Alluminio
Solid Brass/Aluminium

Double Finishes

CRCS/CR

CSCR/CS

NSCR/NS

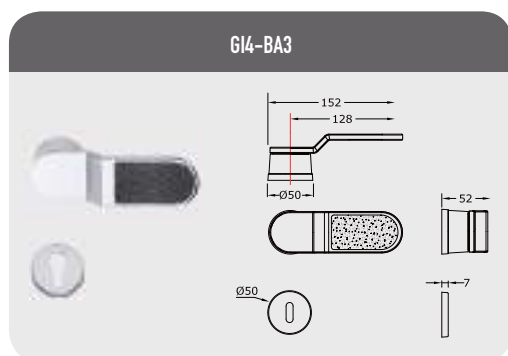

GI4-BA3

Maniglia con
inserto in pelle
di Razza nera
Lever handle with
black Razza fish
insert

Maniglia con rosetta/bocchetta
Lever on rose and key hole

 n. 1 set



mariani

ICE 5 RUB

design: Studio Mariani



CR

CS

Base Material:
Ottone/Alluminio
Solid Brass/Aluminium

Double Finishes

CRCS/CR

CSCR/CS

NSCR/NS

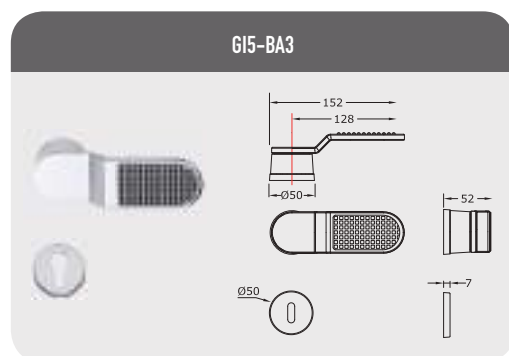

Maniglia con
inserto Inox
e rilievi in
gomma (Ve.142)
Lever handle
with inox insert
and rubber
prominence

Maniglia con rosetta/bocchetta
Lever on rose and key hole

 n. 1 set



mariani

**ICE 5
NIGHT SHOT**
design: Studio Mariani



CR

CS

Base Material:
Ottone/Alluminio
Solid Brass/Aluminium

Double Finishes

CRCS/CR

CSCR/CS

NSCR/NS

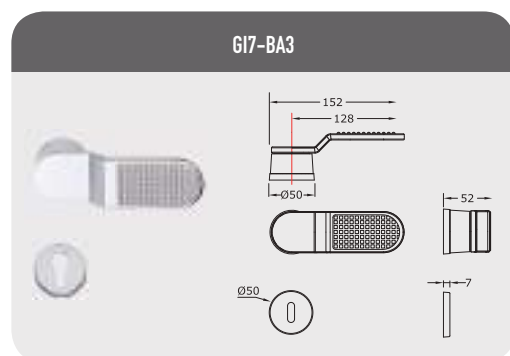

Maniglia con rosetta/bocchetta
Lever on rose and key hole

 n. 1 set

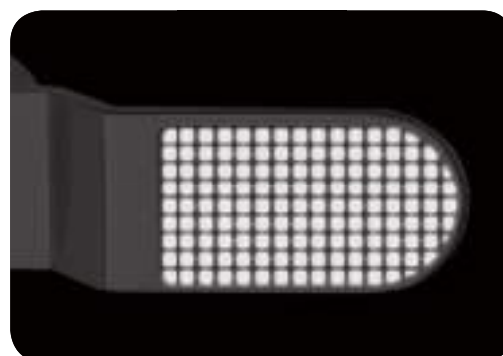

Maniglia con
inserto Inox e
rilievi in gomma
luminescente
Lever handle with
luminescent rubber
in inox insert



mariani

ICE 6 SW
design: Studio Mariani



CR

CS

Base Material:
Ottone/Alluminio/Cristallo
Solid Brass/Aluminium/Crystal

Double Finishes

CRCS/CR

CSCR/CS

NSCR/NS

ICE 6 SW

Made with
CRYSTALLIZED™ - Swarovski Elements

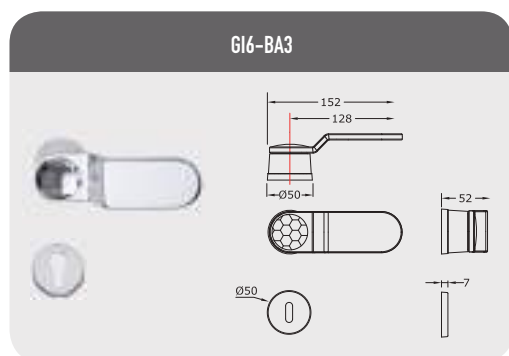

Maniglia con rosetta/bocchetta
Lever on rose and key hole

n. 1 set

mariani

SCAN

design: Lucidi Pevere



CR

CS

NS

Base Material:

Alluminio - Aluminium



LSK-BA3

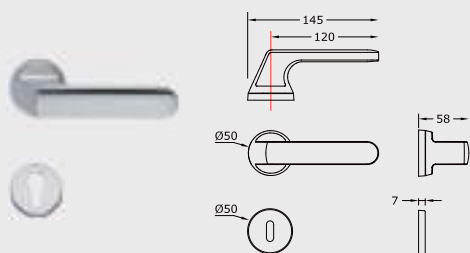

Maniglia con rosetta/bocchetta
Lever on rose and key hole

 n. 1 set



mariani

SINUA

design: Lucidi Pevere



CR

CS

NS

Base Material:
Alluminio - Aluminium

LSN-BA3

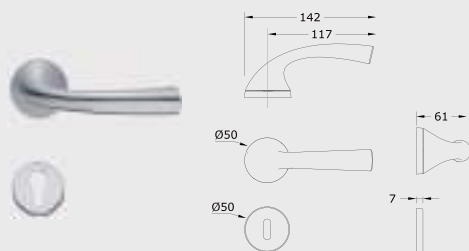

Maniglia con rosetta/bocchetta
Lever on rose and key hole

 n. 1 set



mariani

SOUND

design:
Gianfranco Melegari



CR

CS

NS

Base Material:
Alluminio - Aluminium

LSD-BA3

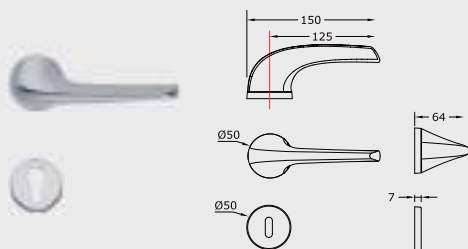

Maniglia con rosetta/bocchetta
Lever on rose and key hole

 n. 1 set

ABE SCHEMI DI MONTAGGIO STANDARD ED A RICHIESTA - ABE MOUNTING EXAMPLES STANDARD AND ON REQUEST

01 - Standard

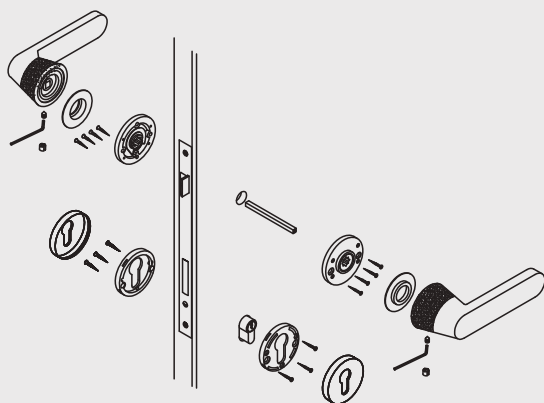

03 - A richiesta - On request

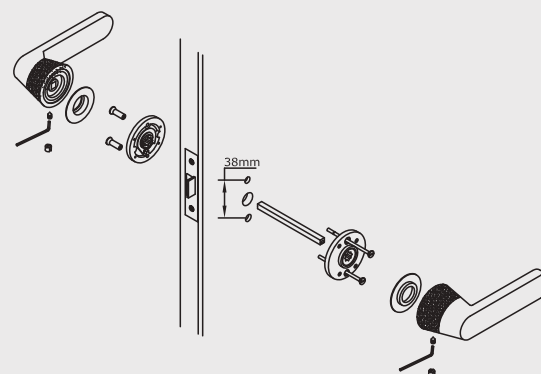

02 - A richiesta - On request

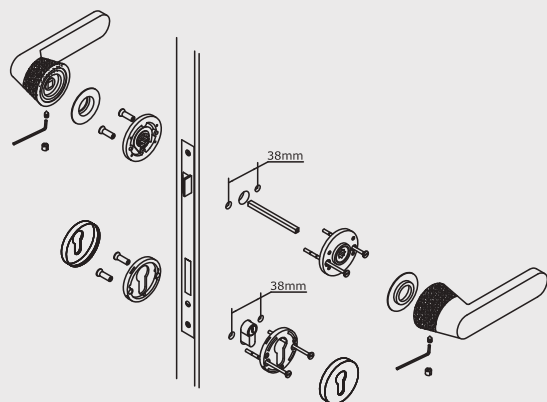

Rosetta/Bocchetta - Rose/Key hole

A richiesta versione con bussole
On request version with bushing

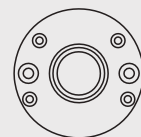
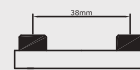

Rose

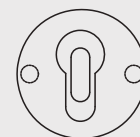

Key hole FC/Yale

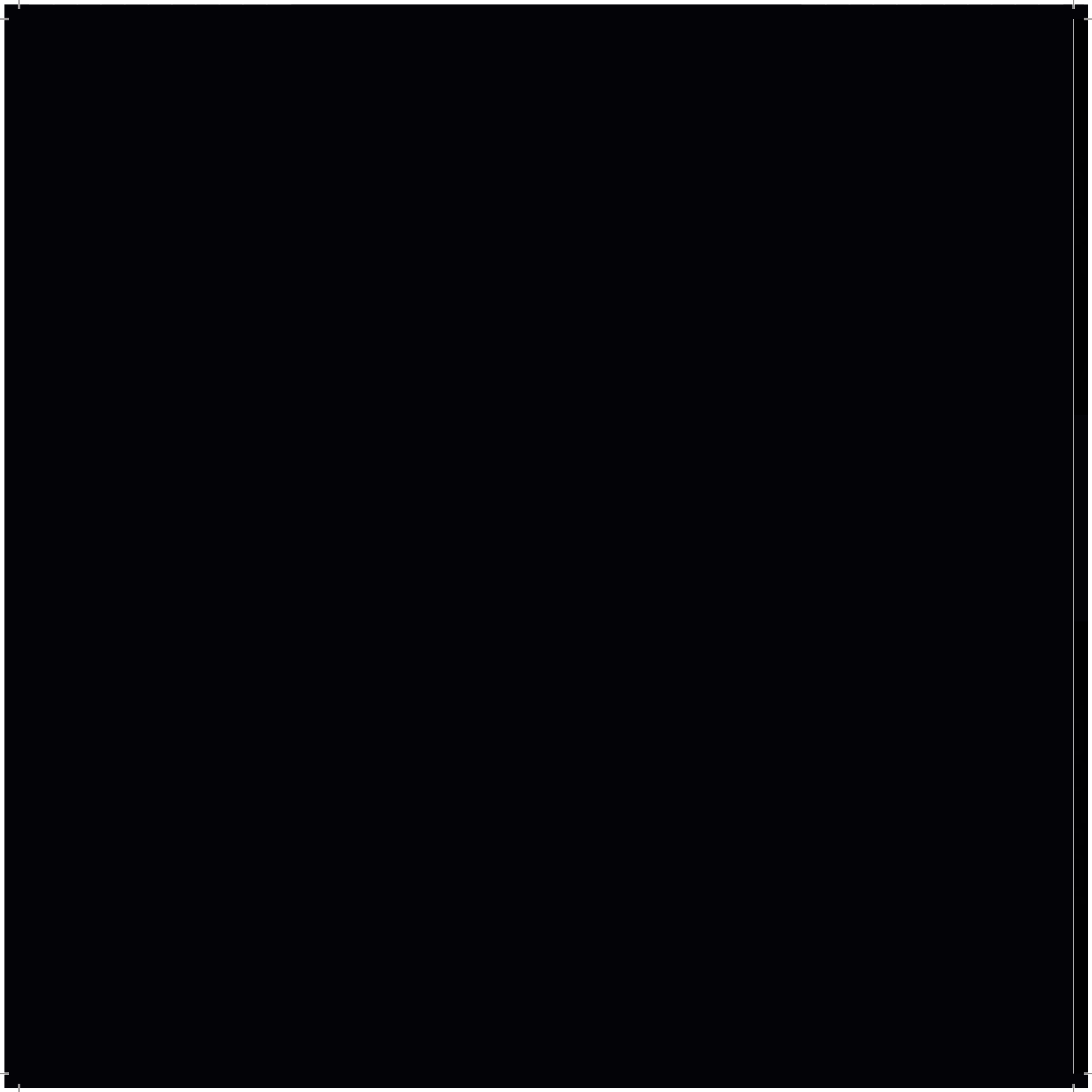

DESIGN MARIANDESIGN MARIANDESIGN
MARIANDESIGN MARIANDESIGN MARIANDESIGN
MARIANDESIGN MARIANDESIGN MARIANDESIGN
DESIGN MARIANDESIGN MARIANDESIGN MARIANDESIGN

MANIGLIE LEVERS



DESIGN MARIANDESIGN MARIANDESIGN MARIANDESIGN
MARIANDESIGN MARIANDESIGN MARIANDESIGN MARIANDESIGN
DESIGN MARIANDESIGN MARIANDESIGN MARIANDESIGN
MARIANDESIGN MARIANDESIGN MARIANDESIGN MARIANDESIGN



mariani

ARTE
design: After Design



CR

CS

NS

YEB

Base Material:
Solid Brass - Ottone

GA5-AAI

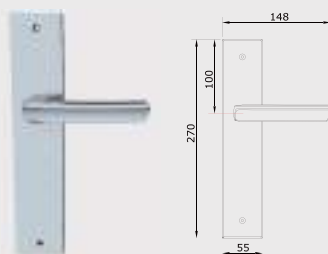

Maniglia con placca Libra
Lever on libra plate

n. 1 set

GA5-BAD

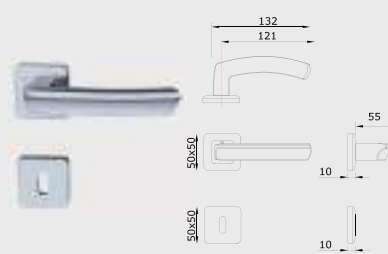

Maniglia con rosetta/bocchetta Qbe
Lever on Qbe rose and key hole

n. 1 set

GA5-DDD-DX / GA5-DCD-SX



Maniglia con Dreh-Kipp Qbe
Lever on Qbe Dreh-Kipp

n. 2 pz



mariani

CLOUD

design: Studio Mariani



CR

CS

NS

YEB

Base Material:
Solid Brass - Ottone

GCD-AAI

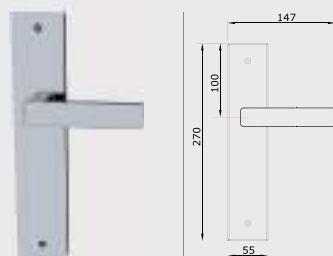

Maniglia con placca Libra
Lever on libra plate

 n. 1 set

GCD-BAD

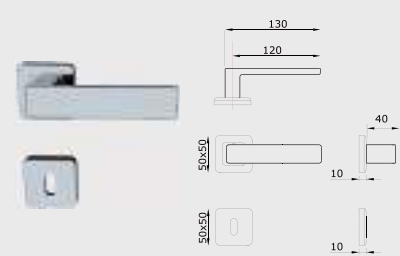

Maniglia con rosetta/bocchetta Qbe
Lever on Qbe rose and key hole

 n. 1 set

GCD-DAD

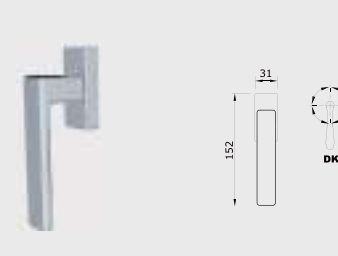

Maniglia con Dreh-Kipp Qbe
Lever on Qbe Dreh-Kipp

 n. 2 pz



mariani[®]

CLOUD 2 RUB
design: Studio Mariani



CR

CS

NS

Base Material:
Solid Brass - Ottone

Maniglia con inserto Inox
e rilievi in gomma (Ve.142)
Lever handle with inox insert
and rubber prominence

GC2-AAI

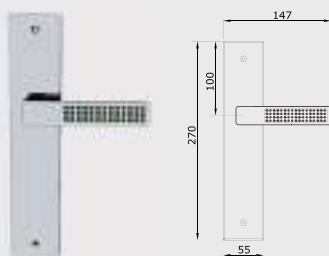

Maniglia con placca Libra
Lever on libra plate

 n. 1 set

GC2-BAD

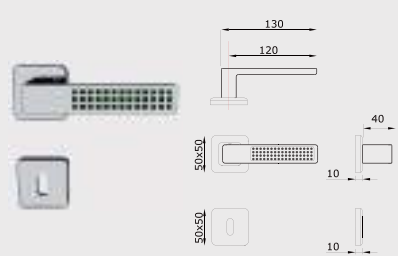

Maniglia con rosetta/bocchetta Qbe
Lever on Qbe rose and key hole

 n. 1 set

GC2-DAD



Maniglia con Dreh-Kipp Qbe
Lever on Qbe Dreh-Kipp

 n. 2 pz

mariani

**CLOUD 2
NIGHT SHOT**
design: Studio Mariani



CR

CS

NS

Base Material:
Solid Brass - Ottone

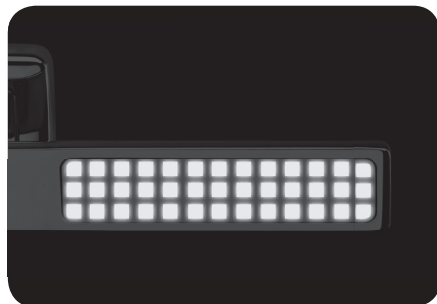

Maniglia con
inserto Inox e
rilievi in gomma
luminescente
Lever handle with
luminescent rubber
in inox insert

GC5-AAI

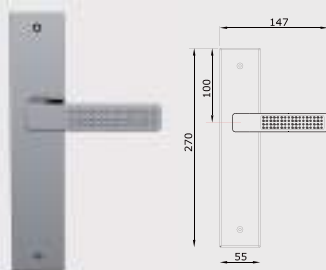

Maniglia con placca Libra
Lever on libra plate

n. 1 set

GC5-BAD

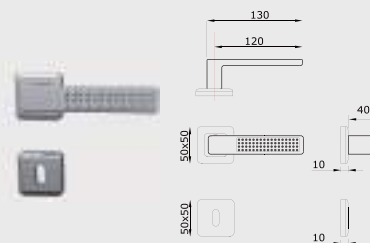

Maniglia con rosetta/bocchetta Qbe
Lever on Qbe rose and key hole

n. 1 set

GC5-DAD



Maniglia con Dreh-Kipp Qbe
Lever on Qbe Dreh-Kipp

n. 2 pz



mariani[®]

CLOUD 3 LEATHER

design: Studio Mariani



CR

CS

NS

Base Material:
Solid Brass - Ottone

Maniglia con inserto in cuoio
naturale trama lucertola nero
Lever handle with in
leather dark lizard texture

GC3-AAI

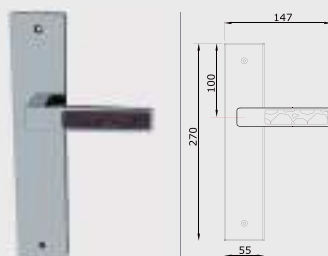

Maniglia con placca Libra
Lever on libra plate

n. 1 set

GC3-BAD

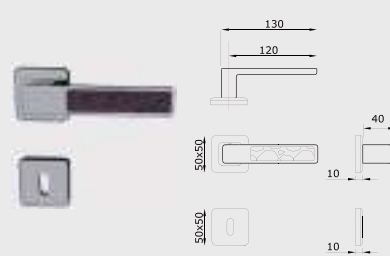

Maniglia con rosetta/bocchetta Qbe
Lever on Qbe rose and key hole

n. 1 set

GC3-DAD

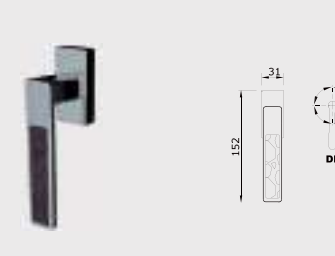

Maniglia con Dreh-Kipp Qbe
Lever on Qbe Dreh-Kipp

n. 2 pz

mariani

CLOUD 4 SW

design: Studio Mariani



CR

CS

NS

Base Material:
Solid Brass - Crystal
Ottone - Cristallo



CLOUD 4 SW

Made with

CRYSTALLIZED™ - Swarovski Elements

GC4-AAI

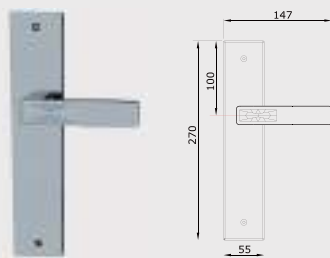

Maniglia con placca Libra
Lever on libra plate

n. 1 set

GC4-BAD

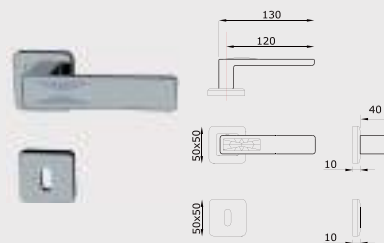

Maniglia con rosetta/bocchetta Qbe
Lever on Qbe rose and key hole

n. 1 set

GC4-DAD

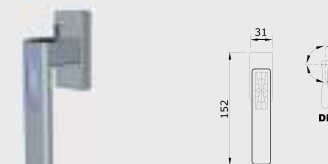

Maniglia con Dreh-Kipp Qbe
Lever on Qbe Dreh-Kipp

n. 2 pz



mariani

COMET

design: Mauro Valsecchi



CR

CS

NS

Base Material:
Solid Brass - Ottone

Double Finishes

CSCR/CRCS

NSNL/NLNS

GCM-AAI

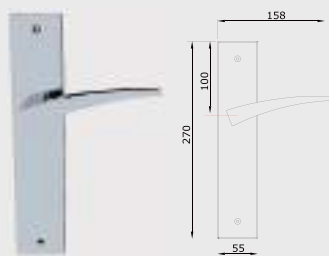

Maniglia con placca Libra
Lever on libra plate

n. 1 set

GCM-BAD

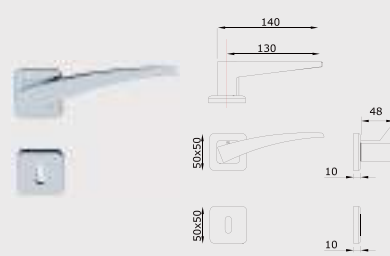

Maniglia con rosetta/bocchetta Qbe
Lever on Qbe rose and key hole

n. 1 set

GCM-DDD-DX / GCM-DCD-SX



Maniglia con Dreh-Kipp Qbe
Lever on Qbe Dreh-Kipp

n. 2 pz



mariani

FUTURA
design: Simone Hybsch



CR

CS

NS

Base Material:
Solid Brass - Ottone

Double Finishes

CSCR/CRCS

GFT-AAI

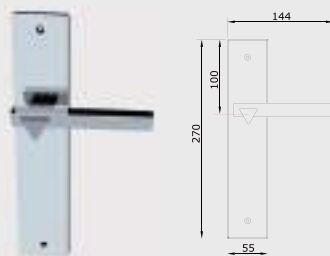

Maniglia con placca Libra
Lever on libra plate

 n. 1 set

GFT-BAD

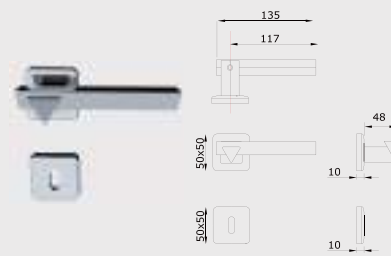

Maniglia con rosetta/bocchetta Qbe
Lever on Qbe rose and key hole

 n. 1 set

GFT-DDD-DX / GFT-DCD-SX

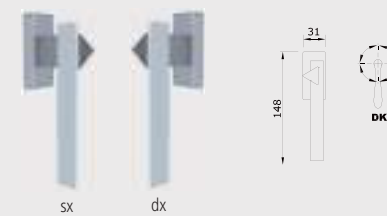

Maniglia con Dreh-Kipp Qbe
Lever on Qbe Dreh-Kipp

 n. 2 pz



mariani

OVER

design:
Gianfranco Melegari



CR

CS

NS

Base Material:
Solid Brass - Ottone

GOE-AAI

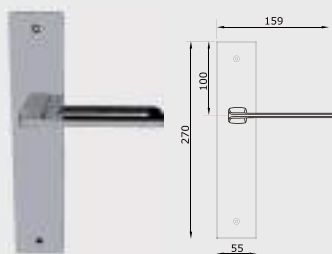

Maniglia con placca Libra
Lever on libra plate

 n. 1 set

GOE-BAD

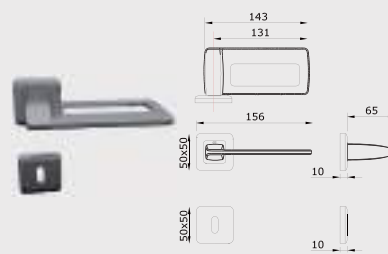

Maniglia con rosetta/bocchetta Qbe
Lever on Qbe rose and key hole

 n. 1 set

GOE-DAD

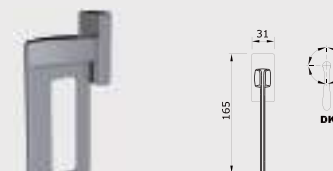

Maniglia con Dreh-Kipp Qbe
Lever on Qbe Dreh-Kipp

 n. 2 pz

mariani

RIVA

design: Lucidi Pevere



CS

CR

NS

Base Material:
Solid Brass - Ottone



GRV-AAI

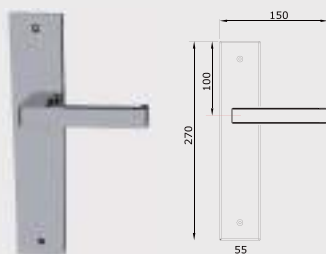

Maniglia con placca Libra
Lever on libra plate

n. 1 set

GRV-BAD

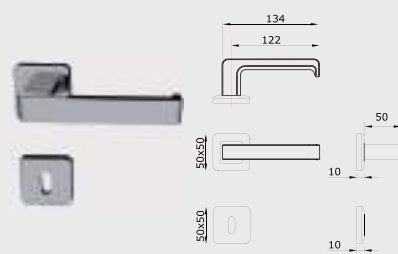

Maniglia con rosetta/bocchetta Qbe
Lever on Qbe rose and key hole

n. 1 set

GRV-DAD

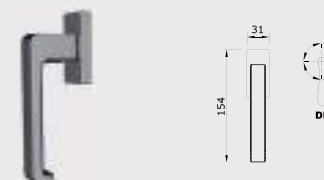

Maniglia con Dreh-Kipp Qbe
Lever on Qbe Dreh-Kipp

n. 2 pz



mariani

SARA
design: Studio Mariani



CR

CS

NS

YEB

Base Material:
Solid Brass - Ottone

GSA-AAI

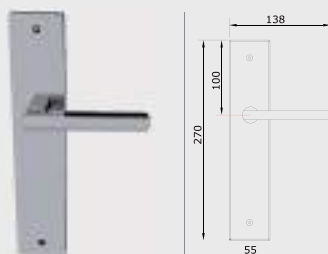

Maniglia con placca Libra
Lever on libra plate

n. 1 set

GSA-BAD

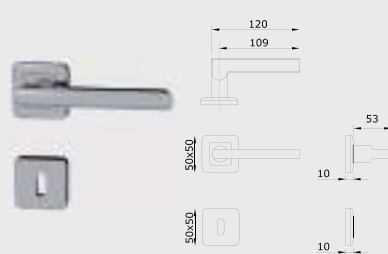

Maniglia con rosetta/bocchetta Qbe
Lever on Qbe rose and key hole

n. 1 set

GSA-DAD

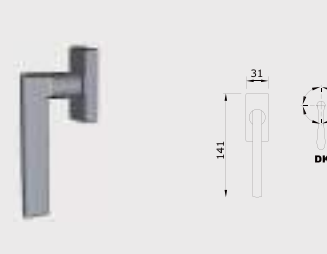

Maniglia con Dreh-Kipp Qbe
Lever on Qbe Dreh-Kipp

n. 2 pz

mariani

SOFT

design: Lucidi Pevere



CS

CR

NS

YEB

Base Material:
Solid Brass - Ottone



GS7-AAI

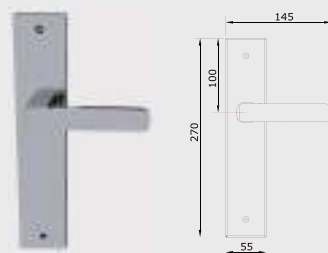

Maniglia con placca Libra
Lever on libra plate

n. 1 set

GS7-BAD

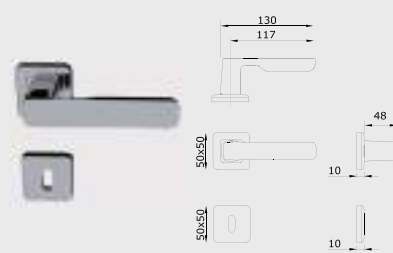

Maniglia con rosetta/bocchetta Qbe
Lever on Qbe rose and key hole

n. 1 set

GS7-DAD

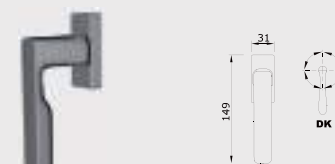

Maniglia con Dreh-Kipp Qbe
Lever on Qbe Dreh-Kipp

n. 2 pz



mariani

SUN

design: Studio Mariani



CR

CS

NS

Base Material:
Solid Brass - Ottone

Double Finishes

CSCR/CRCs

NSNL/NLNS

GSU-AAI

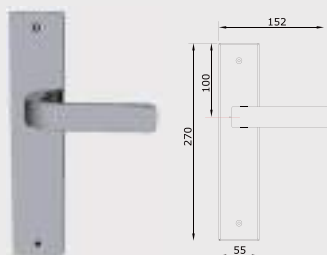

Maniglia con placca Libra
Lever on libra plate

n. 1 set

GSU-BAD

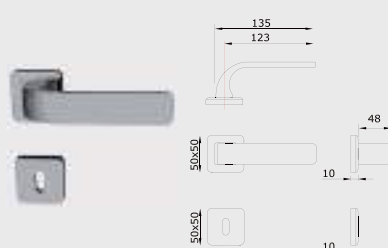

Maniglia con rosetta/bocchetta Qbe
Lever on Qbe rose and key hole

n. 1 set

GSU-DAD



Maniglia con Dreh-Kipp Qbe
Lever on Qbe Dreh-Kipp

n. 2 pz

mariani

SUN 2

design: Studio Mariani



CR

CS

NS

Base Material:
Solid Brass - Ottone



GS2-AAI

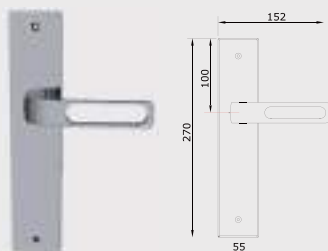

Maniglia con placca Libra
Lever on libra plate

n. 1 set

GS2-BAD

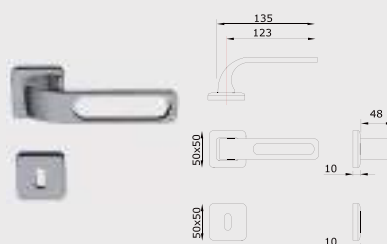

Maniglia con rosetta/bocchetta Qbe
Lever on Qbe rose and key hole

n. 1 set

GS2-DAD

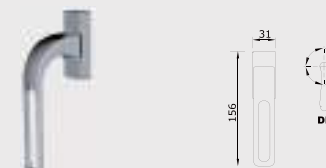

Maniglia con Dreh-Kipp Qbe
Lever on Qbe Dreh-Kipp

n. 2 pz



mariani

SUN 3

design: Studio Mariani



CR

CS

NS

Base Material:
Solid Brass - Ottone

GS3-AAI

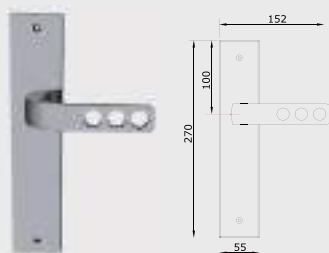

Maniglia con placca Libra
Lever on libra plate

 n. 1 set

GS3-BAD

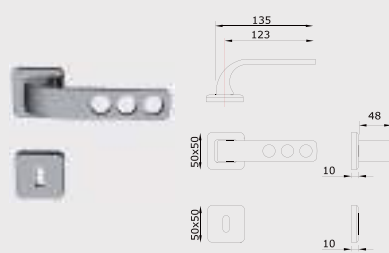

Maniglia con rosetta/bocchetta Qbe
Lever on Qbe rose and key hole

 n. 1 set

GS3-DAD

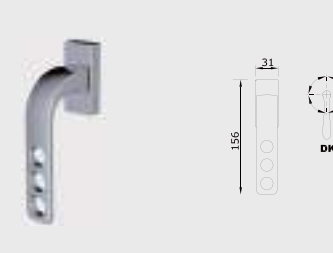

Maniglia con Dreh-Kipp Qbe
Lever on Qbe Dreh-Kipp

 n. 2 pz



mariani

SUN 4 SW

design: Studio Mariani



CR

CS

NS

Base Material:
Solid Brass - Crystall
Ottone - Cristallo

SUN 4 SW

Made with

CRYSTALLIZED™ - Swarovski Elements

GS4-AAI

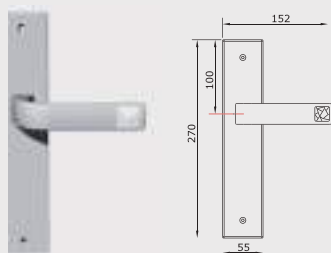

Maniglia con placca Libra
Lever on libra plate

 n. 1 set

GS4-BAD

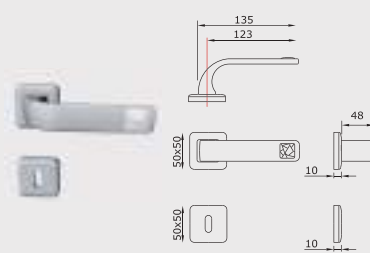

Maniglia con rosetta/bocchetta Qbe
Lever on Qbe rose and key hole

 n. 1 set

GS4-DAD



Maniglia con Dreh-Kipp Qbe
Lever on Qbe Dreh-Kipp

 n. 2 pz



mariani

ZENITH

design:
Gianfranco Melegari



CS

CR

NS

YEB

Base Material:
Solid Brass - Ottone

GZH-AAI

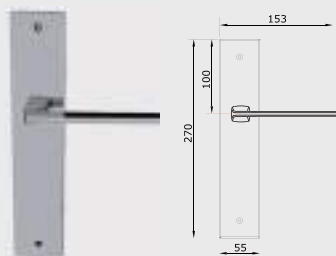

Maniglia con placca Libra
Lever on libra plate

n. 1 set

GZH-BAD

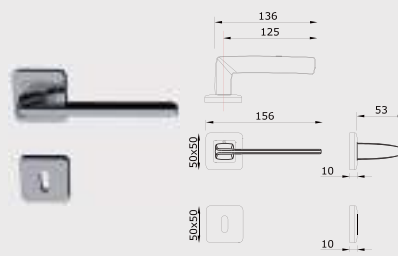

Maniglia con rosetta/bocchetta Qbe
Lever on Qbe rose and key hole

n. 1 set

GZH-DAD



Maniglia con Dreh-Kipp Qbe
Lever on Qbe Dreh-Kipp

n. 2 pz

SCHEMI PER MANIGLIE CON ROSETTA QBE STANDARD ED A RICHIESTA - SCHEMES FOR LEVER ON QBE ROSE STANDARD AND ON REQUEST

RO - 01 - Standard

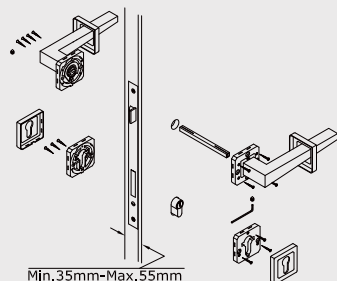

RO - 03 - A richiesta - On request

Privacy antipanico
Privacy antipanic

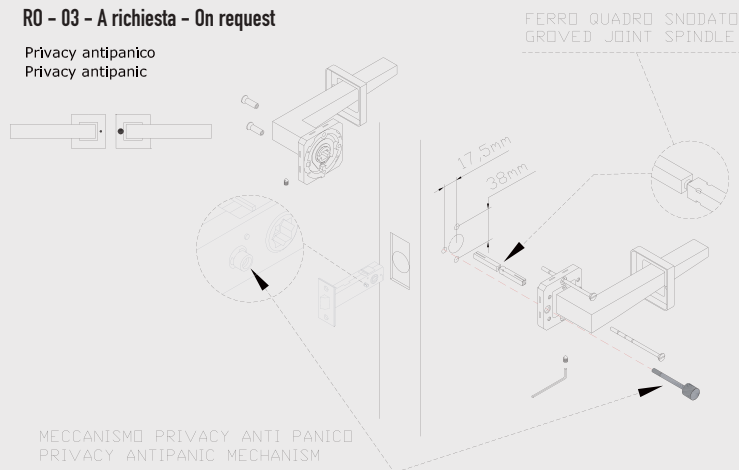

RO - 02 - A richiesta - On request

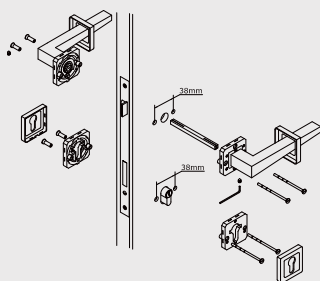

RO - 05 - A richiesta - On request

Maniglie su rosetta + bocchetta WC
Lever on rose with turn and release

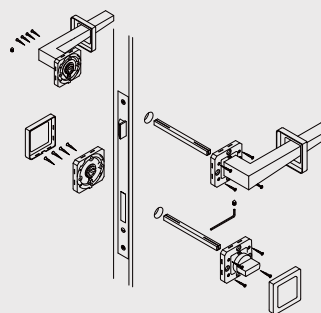

RO - 06 - A richiesta - On request

Sistema pomolo esterno fisso e maniglia interna girevole su rosette
System for outside fixed knob and inside working lever and rose

Sistema pomolo esterno fisso e maniglia interna girevole su rosette

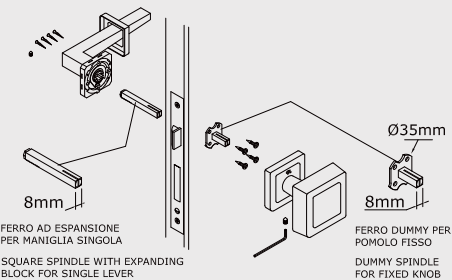

RO - 03 - A richiesta - On request

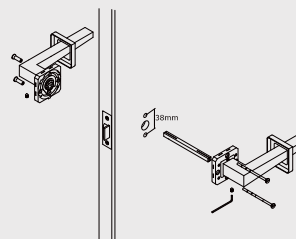

RO - 07 - A richiesta - On request

Maniglie su rosetta e bocchetta stretta.
Levers on narrow rose and escutcheon

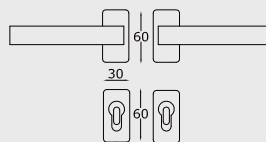

Rosetta/Bocchetta - Rose/Key hole

A richiesta versione con bussole
On request versión with bushing

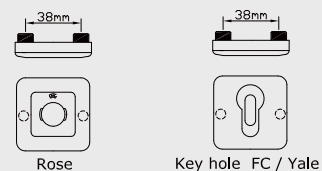

SCHEMI MANIGLIA CON PLACCA STANDARD A RICHIESTA - SCHEMES FOR LEVER ON PLATE STANDARD AND ON REQUEST

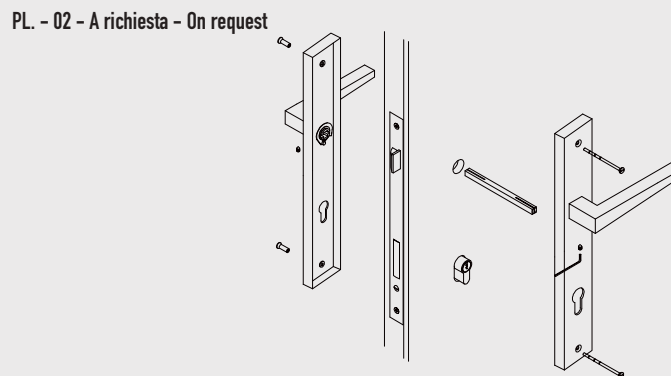
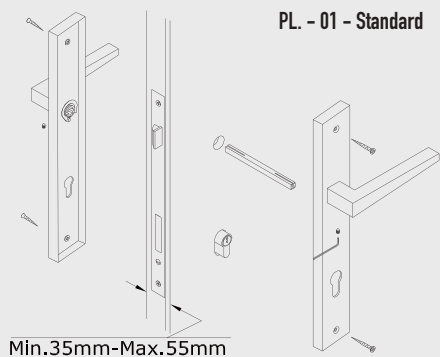
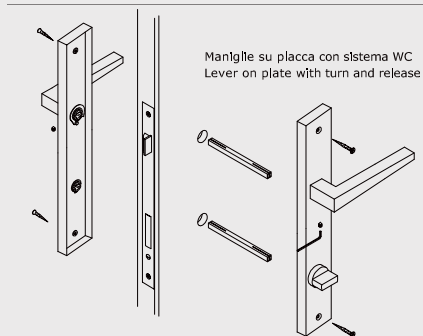
**PL. - 03 - A richiesta - On request****PL. - 04 - A richiesta - On request**

Sistema pomolo esterno fisso e maniglia interna
girevole su placche
System for outside fixed knob and Inside working
lever and plate

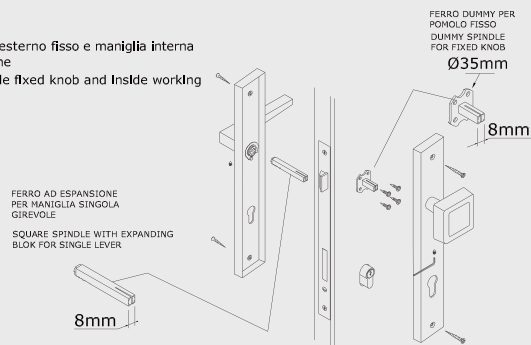

SCHEMA DK - SCHEMES FOR DK

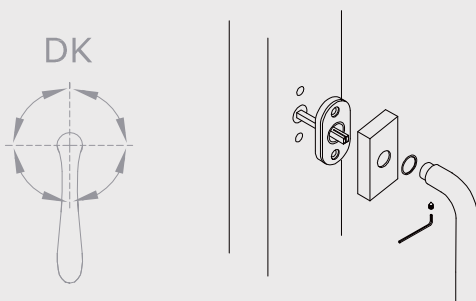
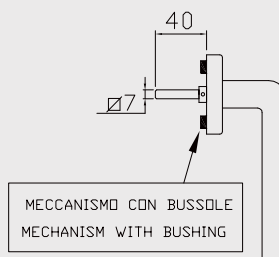
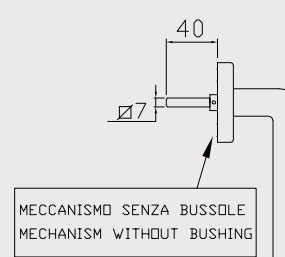
**DK - 01 - Standard****DK - 02 - A richiesta - On request**

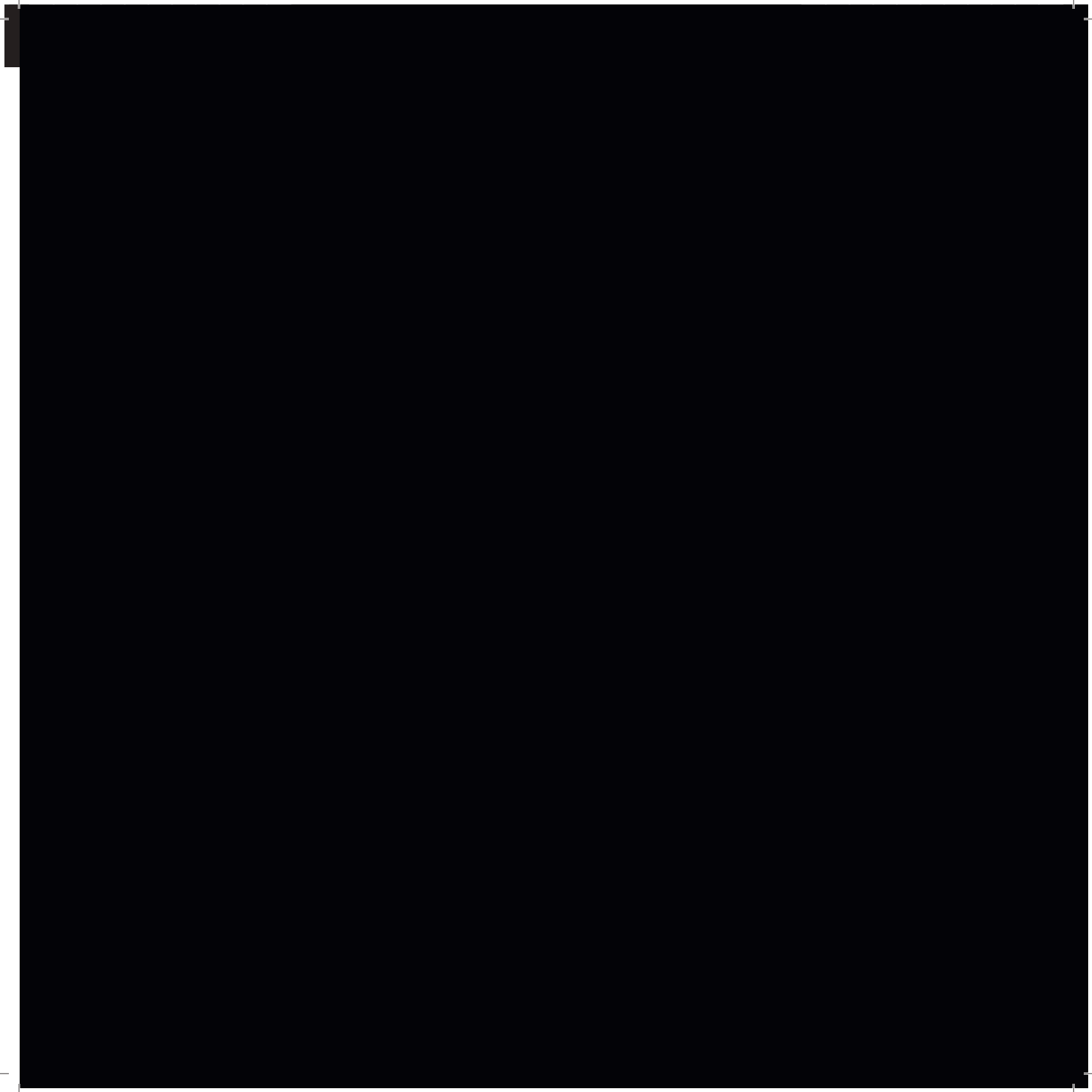

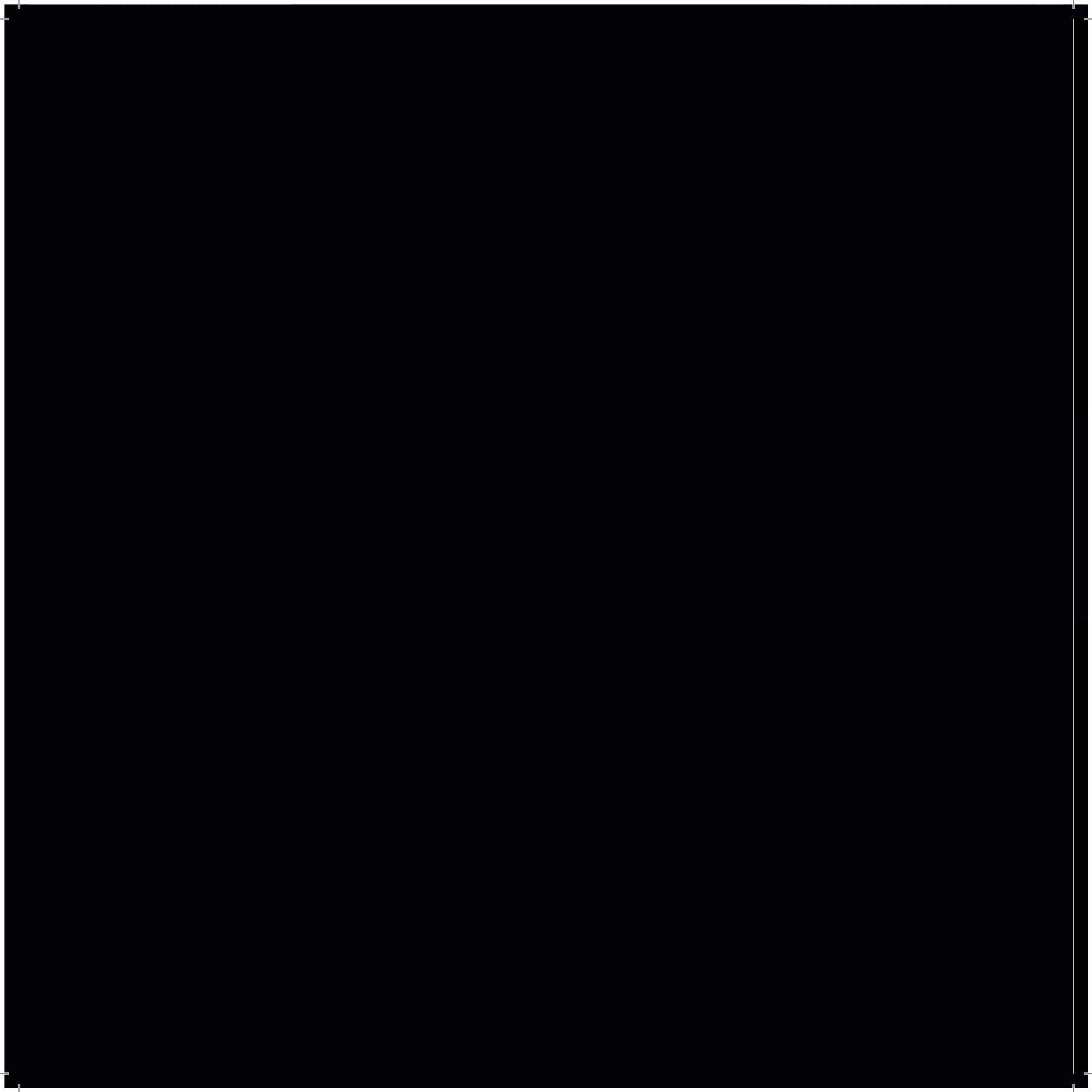



mariani

ADRIANA



OLV

CS

Base Material:
Solid Brass - Ottone

GA7-AAS

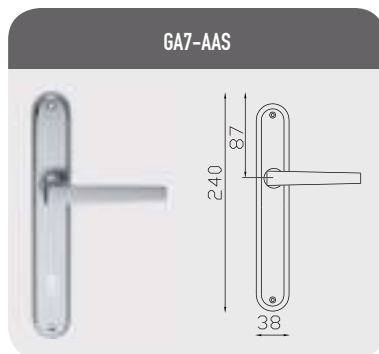

Maniglia con placca Astra
Lever on Astra plate

 n. 1 set

GA7-BAR

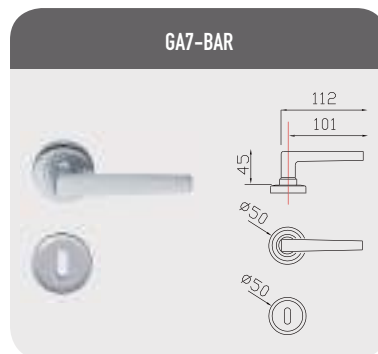

Maniglia con rosetta/bocchetta Artax
Lever on Artax rose and key hole

 n. 1 set

GA7-DAN



Maniglia con Dreh-Kipp Nika
Lever on Nika Dreh-Kipp

 n. 2 pz

GA7-LMT



Cremonese/Martellina con placca Thalassia C.V.
Movimento non incluso nel prezzo
Cremon/Martellina on Thalassia screw cover plate
Price of mechanism not included

 n. 2 pz

mariani

ASIA

design:
Gianfranco Melegari



OLV

CS

YEB

Base Material:
Solid Brass - Ottone



GAA-AAW



Maniglia con placca Asia
Lever on Asia plate

n. 1 set

GAA-BAR

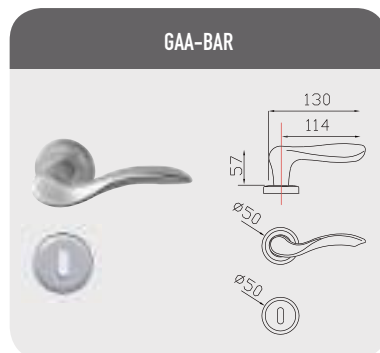

Maniglia con rosetta/bocchetta Artax
Lever on Artax rose and key hole

n. 1 set

GAA-DDN-DX / GAA-DCN-SX

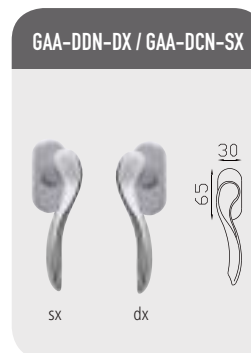

Maniglia con Dreh-Kipp Nika
Lever on Nika Dreh-Kipp n. 2 pz

GON-LLT



Onda cremonese/Martellina con placca Thalassia C.V.
Movimento non incluso nel prezzo
Onda cremon/Martellina on Thalassia screw cover plate
Price of mechanism not included

n. 2 pz



mariani

BONN
design: Studio Mariani



Base Material:
Solid Brass - Stainless steel
Ottone - Acciaio inox

Double Finishes

INSCR/CR

IPSOLV/OLV

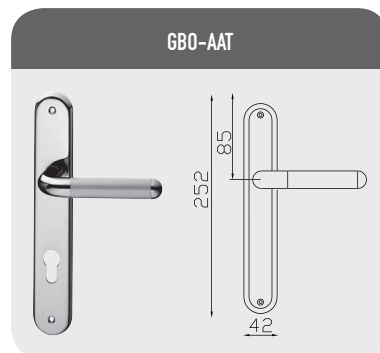

Maniglia con placca Thalassia
Lever on Thalassia plate

 n. 1 set

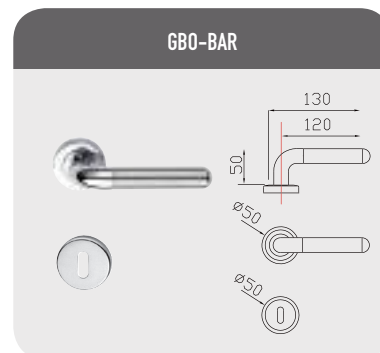

Maniglia con rosetta/bocchetta Artax
Lever on Artax rose and key hole

 n. 1 set

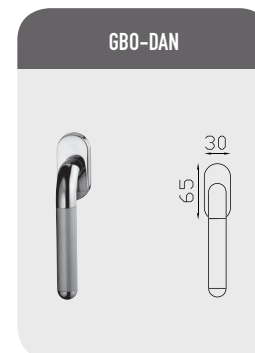

Maniglia con Dreh-Kipp Nika
Lever on Nika Dreh-Kipp  n. 2 pz

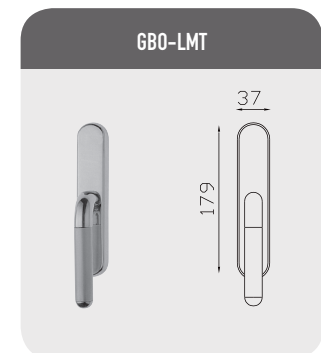

Cremonese/Martellina con placca Thalassia C.V.
Movimento non incluso nel prezzo
Cremon/Martellina on Thalassia screw cover plate
Price of mechanism not included

 n. 2 pz



mariani

DARIA



OLV

CS

Base Material:
Solid Brass - Ottone

**ELIMINATA
NO MORE AVAILABLE**

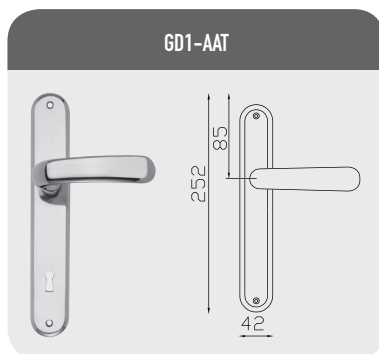

Maniglia con placca Thalassia
Lever on Thalassia plate

n. 1 set

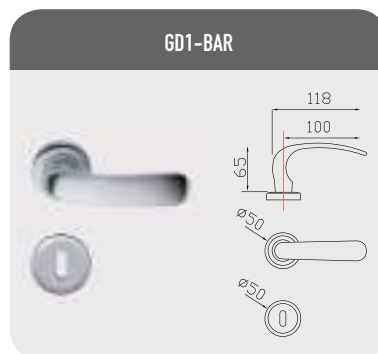

Maniglia con rosetta/bocchetta Artax
Lever on Artax rose and key hole

n. 1 set

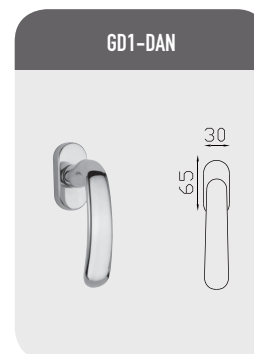

Maniglia con Dreh-Kipp Nika
Lever on Nika Dreh-Kipp n. 2 pz



Cremonese/Martellina con placca Thalassia C.V.
Movimento non incluso nel prezzo
Cremon/Martellina on Thalassia screw cover plate
Price of mechanism not included

n. 2 pz



mariani

DIANA



OLV

CS

Base Material:
Solid Brass - Ottone

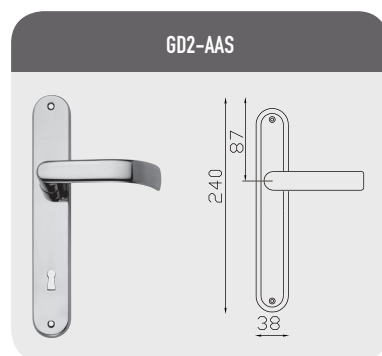

Maniglia con placca Astra
Lever on Astra plate

n. 1 set

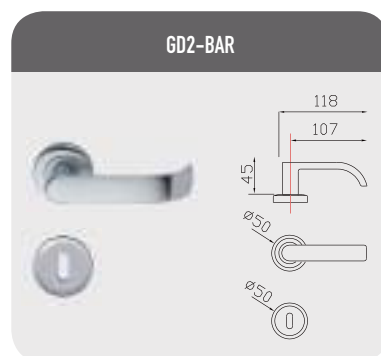

Maniglia con rosetta/bocchetta Artax
Lever on Artax rose and key hole

n. 1 set



Maniglia con Dreh-Kipp Nika
Lever on Nika Dreh-Kipp n. 2 pz



Cremonese/Martellina con placca Thalassia C.V.
Movimento non incluso nel prezzo
Cremon/Martellina on Thalassia screw cover plate
Price of mechanism not included

n. 2 pz

mariani

EGLE



OLV

CS

Base Material:
Solid Brass - Ottone

**ELIMINATO
NO MORE AVAILABLE**

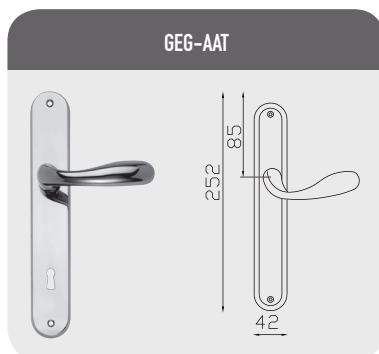

Maniglia con placca Thalassia
Lever on Thalassia plate

n. 1 set



Maniglia con rosetta/bocchetta Artax
Lever on Artax rose and key hole

n. 1 set

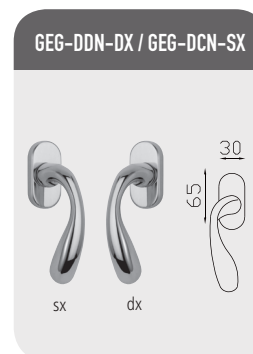

Maniglia con Dreh-Kipp Nika
Lever on Nika Dreh-Kipp n. 2 pz



mariani

GOCCIA
design: Mauro Ronchi



OLV

CS

Base Material:
Solid Brass - Ottone

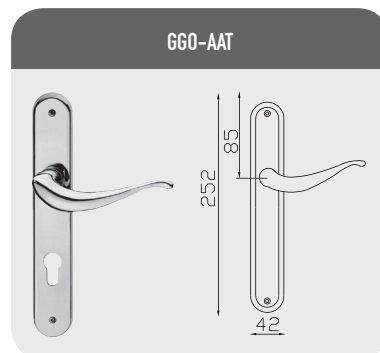

Maniglia con placca Thalassia
Lever on Thalassia plate

n. 1 set

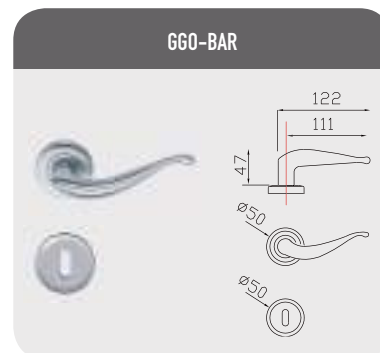

Maniglia con rosetta/bocchetta Artax
Lever on Artax rose and key hole

n. 1 set

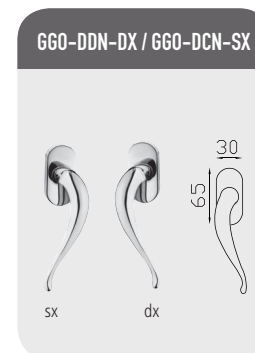

Maniglia con Dreh-Kipp Nika
Lever on Nika Dreh-Kipp n. 2 pz



Kira cremonese/Martellina con placca Thalassia C.V.
Movimento non incluso nel prezzo
Kira cremon/Martellina on Thalassia screw cover plate
Price of mechanism not included

n. 2 pz

mariani

GOLF

design: Studio Mariani



OLV

CS

YEB

Base Material:
Solid Brass - Ottone



GGL-AAW



Maniglia con placca Asia
Lever on Asia plate

 n. 1 set

GGL-BAR



Maniglia con rosetta/bocchetta Artax
Lever on Artax rose and key hole

 n. 1 set



mariani

JENNY



OLV

CS

CR

Base Material:
Solid Brass - Ottone

GJN-AAT

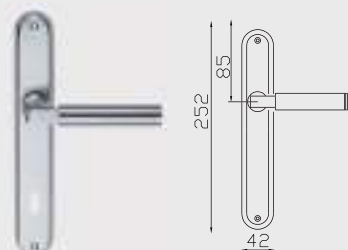

Maniglia con placca Thalassia
Lever on Thalassia plate

 n. 1 set

GJN-BAR

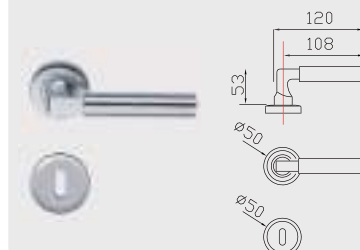

Maniglia con rosetta/bocchetta Artax
Lever on Artax rose and key hole

 n. 1 set

GJN-DAN



Maniglia con Dreh-Kipp Nika
Lever on Nika Dreh-Kipp  n. 2 pz

GJN-LMT

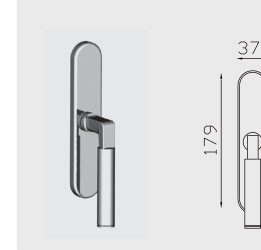

Cremonese/Martellina con placca Thalassia C.V.
Movimento non incluso nel prezzo
Cremon/Martellina on Thalassia screw cover plate
Price of mechanism not included

 n. 2 pz

mariani

JULIA



OLV

CS

Base Material:
Solid Brass - Ottone

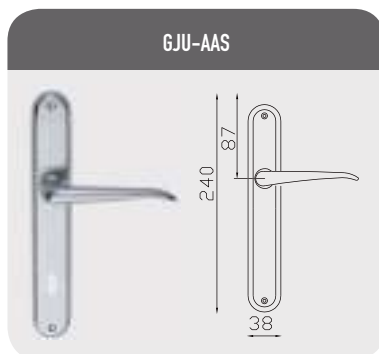

Maniglia con placca Astra
Lever on Astra plate

n. 1 set



Maniglia con rosetta/bocchetta Artax
Lever on Artax rose and key hole

n. 1 set

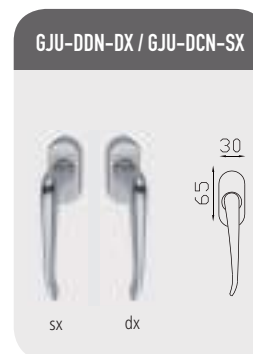

Maniglia con Dreh-Kipp Nika

Lever on Nika Dreh-Kipp n. 2 pz



Onda cremonese/Martellina con placca Thalassia C.V.
Movimento non incluso nel prezzo
Onda cremon/Martellina on Thalassia screw cover plate
Price of mechanism not included

n. 2 pz



mariani

LAGUNA

design: Studio Mariani



OLV

CS

Base Material:
Solid Brass - Ottone

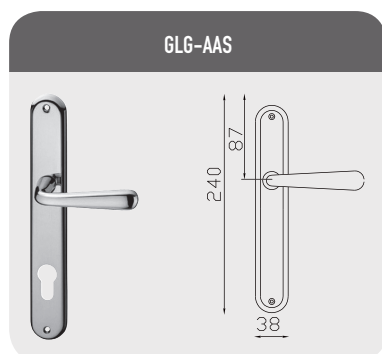

Maniglia con placca Astra
Lever on Astra plate

 n. 1 set



Maniglia con rosetta/bocchetta Artax
Lever on Artax rose and key hole

 n. 1 set



Maniglia con Dreh-Kipp Nika
Lever on Nika Dreh-Kipp  n. 2 pz

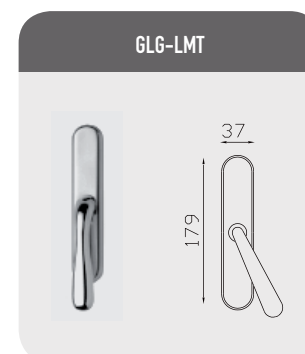

Cremonese/Martellina con placca Thalassia C.V.
Movimento non incluso nel prezzo
Cremon/Martellina on Thalassia screw cover plate
Price of mechanism not included

 n. 2 pz

mariani

LISA



OLV

CS

Base Material:
Solid Brass - Ottone

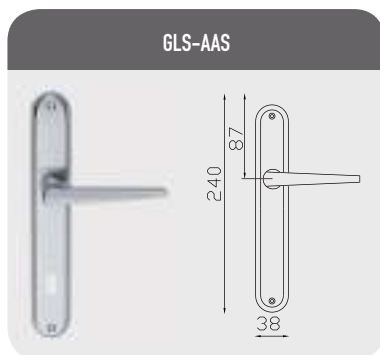

Maniglia con placca Astra
Lever on Astra plate

n. 1 set



Maniglia con rosetta/bocchetta Artax
Lever on Artax rose and key hole

n. 1 set

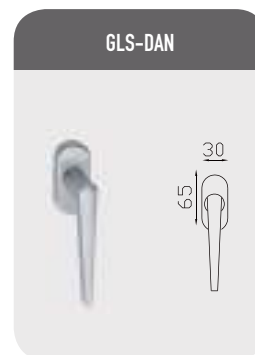

Maniglia con Dreh-Kipp Nika

Lever on Nika Dreh-Kipp n. 2 pz



Cremonese/Martellina con placca Thalassia C.V.
Movimento non incluso nel prezzo
Cremon/Martellina on Thalassia screw cover plate
Price of mechanism not included

n. 2 pz



mariani

LORELLA



OLV

CS

Base Material:
Solid Brass - Ottone

GL2-AAS

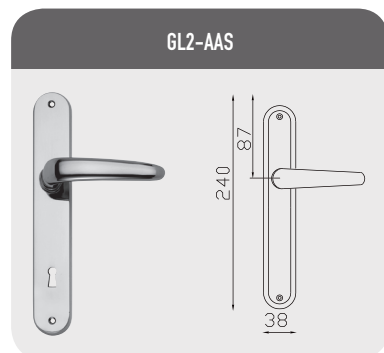

Maniglia con placca Astra
Lever on Astra plate

 n. 1 set

GL2-BAR



Maniglia con rosetta/bocchetta Artax
Lever on Artax rose and key hole

 n. 1 set

GL2-DAN

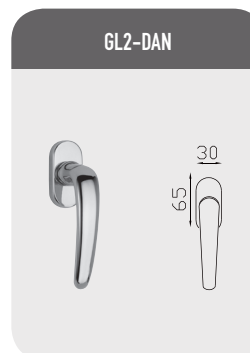

Maniglia con Dreh-Kipp Nika
Lever on Nika Dreh-Kipp  n. 2 pz

GL2-LLT



Cremonese/Martellina con placca Thalassia C.V.
Movimento non incluso nel prezzo
Cremon/Martellina on Thalassia screw cover plate
Price of mechanism not included

 n. 2 pz

mariani

LOTUS
design:
Gianfranco Melegari



OLV

CS

Base Material:
Solid Brass - Ottone

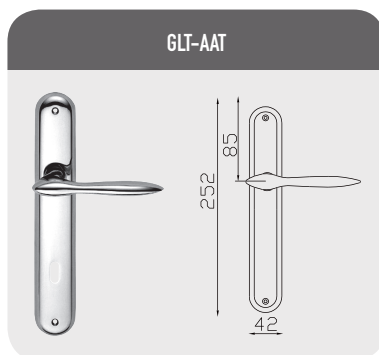

Maniglia con placca Thalassia
Lever on Thalassia plate

n. 1 set

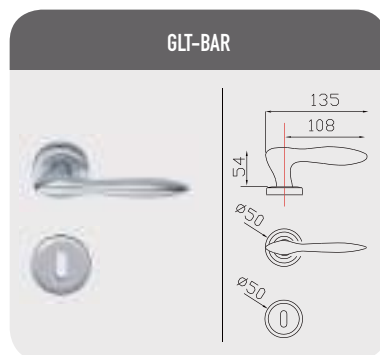

Maniglia con rosetta/bocchetta Artax
Lever on Artax rose and key hole

n. 1 set



Maniglia con Dreh-Kipp Nika
Lever on Nika Dreh-Kipp

n. 2 pz



Kira Cremonese/Martellina con placca Thalassia C.V.
Movimento non incluso nel prezzo
Kira cremon/Martellina on Thalassia screw cover plate
Price of mechanism not included

n. 2 pz



mariani

MARA



OLV

CS

Base Material:
Solid Brass - Ottone

**ELIMINATA
NO MORE AVAILABLE**

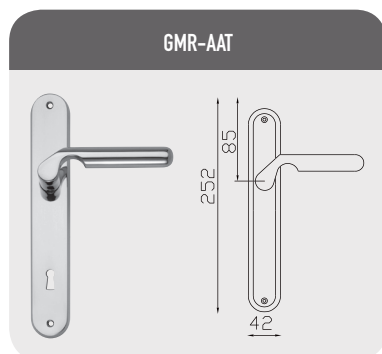

Maniglia con placca Thalassia
Lever on Thalassia plate

 n. 1 set

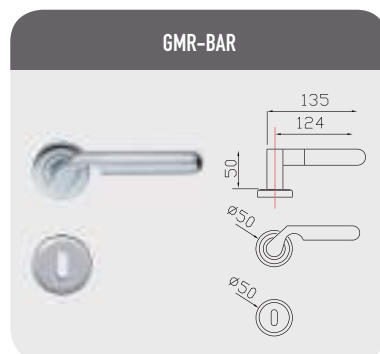

Maniglia con rosetta/bocchetta Artax
Lever on Artax rose and key hole

 n. 1 set

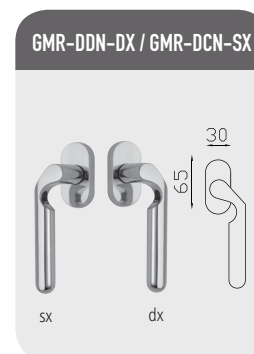

Maniglia con Dreh-Kipp Nika
Lever on Nika Dreh-Kipp  n. 2 pz

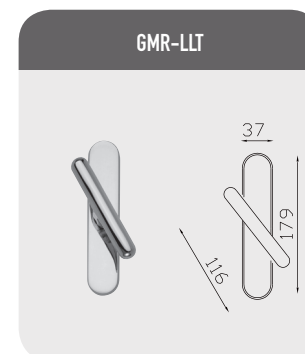

Cremonese/Martellina con placca Thalassia C.V.
Movimento non incluso nel prezzo
Cremon/Martellina on Thalassia screw cover plate
Price of mechanism not included

 n. 2 pz



mariani

MAREA
design: Fulvio Manenti



Base Material:
Solid Brass Plexiglass
Ottone Plexiglass

Double Finishes

CS/M1

CR/M1

DISPONIBILE SOLO CON PLEXIGLASS
COLORE AZZURRO E BLU
AVAILABLE ONLY WITH BLUE AND
LIGHT BLUE PLEXIGLASS.

GM1-BAR



Maniglia con rosetta/bocchetta Artax
Lever on Artax rose and key hole

n. 1 set

GM1-DDN-DX / GM1-DCN-SX

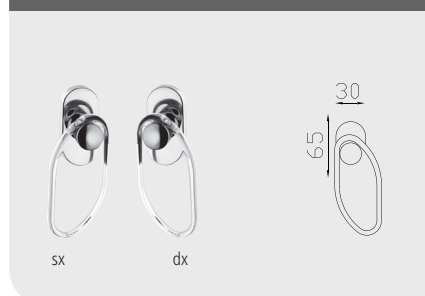

Maniglia con Dreh-Kipp Nika
Lever on Nika Dreh-Kipp

n. 2 pz



mariani

MARIELLA

design: Studio Mariani



CS

CR

NS

Base Material:
Solid Brass - Ottone

GME-AAT

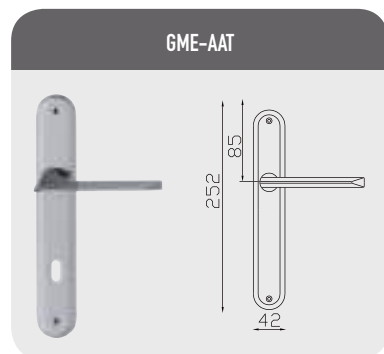

Maniglia con placca Thalassia
Lever on Thalassia plate

 n. 1 set

GME-BAR

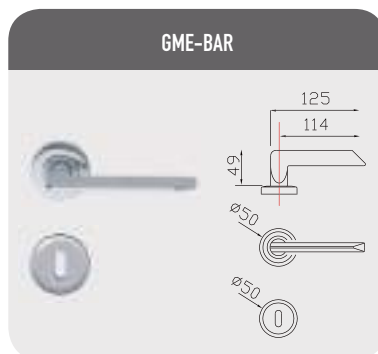

Maniglia con rosetta/bocchetta Artax
Lever on Artax rose and key hole

 n. 1 set

GME-DAN



Maniglia con Dreh-Kipp Nika
Lever on Nika Dreh-Kipp  n. 2 pz

GME-LMT



Cremonese/Martellina con placca Thalassia C.V.
Movimento non incluso nel prezzo
Cremon/Martellina on Thalassia screw cover plate
Price of mechanism not included

 n. 2 pz

mariani[®]

OLIMPO
design: Studio Mariani



OLV

CS

CR

Base Material:
Solid Brass - Ottone



Maniglia con placca Asia
Lever on Asia plate

 n. 1 set

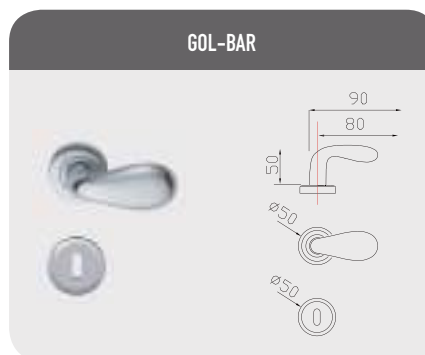

Maniglia con rosetta/bocchetta Artax
Lever on Artax rose and key hole

 n. 1 set



mariani

ONDA
design: Mauro Ronchi



OLV

CS

NS

Base Material:
Solid Brass - Ottone

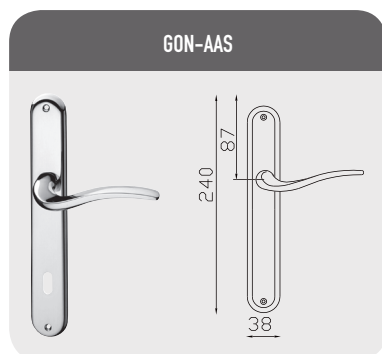

Maniglia con placca Astra
Lever on Astra plate

n. 1 set

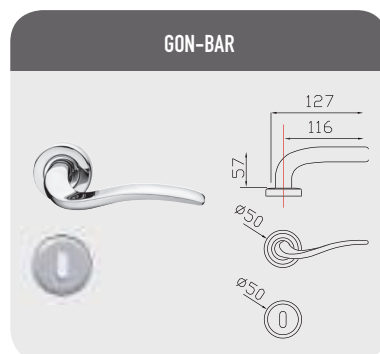

Maniglia con rosetta/bocchetta Artax
Lever on Artax rose and key hole

n. 1 set

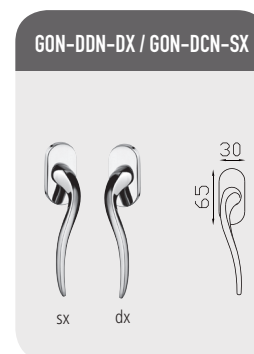

Maniglia con Dreh-Kipp Nika
Lever on Nika Dreh-Kipp n. 2 pz

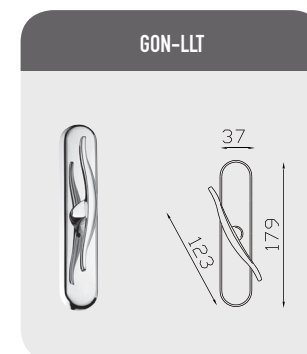

Onda cremonese/Martellina con placca Thalassia C.V.
Movimento non incluso nel prezzo
Onda cremon/Martellina on Thalassia screw cover plate
Price of mechanism not included

n. 2 pz

mariani

PETRA
design: Studio Mariani



OLV

CS

CR

Base Material:
Solid Brass - Ottone

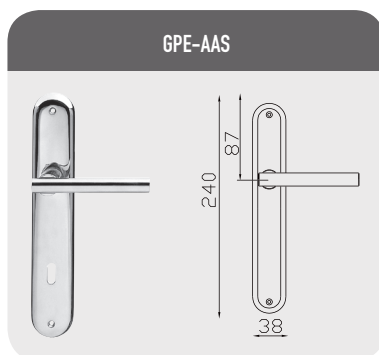

Maniglia con placca Astra
Lever on Astra plate

n. 1 set

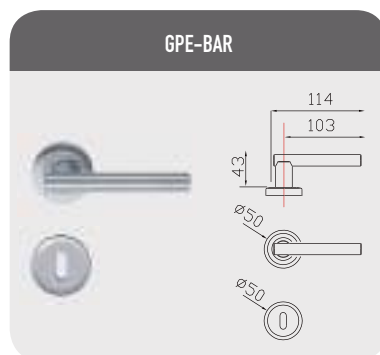

Maniglia con rosetta/bocchetta Artax
Lever on Artax rose and key hole

n. 1 set



Maniglia con Dreh-Kipp Nika
Lever on Nika Dreh-Kipp

n. 2 pz



Cremonese/Martellina con placca Thalassia C.V.
Movimento non incluso nel prezzo
Cremon/Martellina on Thalassia screw cover plate
Price of mechanism not included

n. 2 pz



mariani

SHADOW
design: Studio Mariani



CS

CR

Base Material:
Solid Brass - Ottone

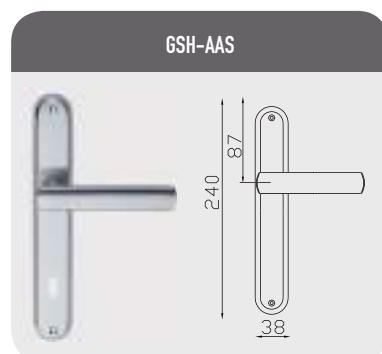

Maniglia con placca Astra
Lever on Astra plate

 n. 1 set

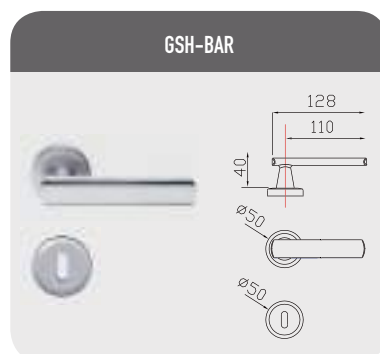

Maniglia con rosetta/bocchetta Artax
Lever on Artax rose and key hole

 n. 1 set



Maniglia con Dreh-Kipp Nika
Lever on Nika Dreh-Kipp  n. 2 pz



Cremonese/Martellina con placca Thalassia C.V.
Movimento non incluso nel prezzo
Cremon/Martellina on Thalassia screw cover plate
Price of mechanism not included

 n. 2 pz

mariani

SILVIA
design: Studio Mariani



OLV

CS

Base Material:
Solid Brass - Ottone

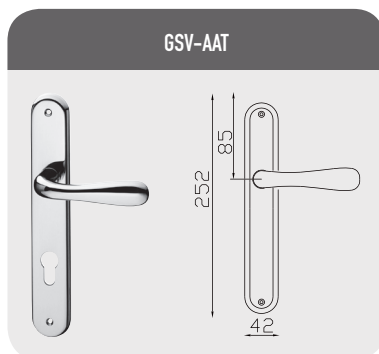

Maniglia con placca Thalassia
Lever on Thalassia plate

n. 1 set



Maniglia con rosetta/bocchetta Artax
Lever on Artax rose and key hole

n. 1 set

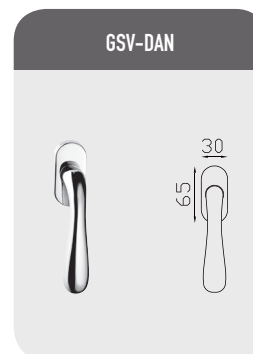

Maniglia con Dreh-Kipp Nika

Lever on Nika Dreh-Kipp n. 2 pz



Cremonese/Martellina con placca Thalassia C.V.
Movimento non incluso nel prezzo
Cremon/Martellina on Thalassia screw cover plate
Price of mechanism not included

n. 2 pz



mariani

SOGNO
design: Fulvio Manenti



Base Material:
Solid Brass Plexiglass
Ottone Plexiglass

Double Finishes

CS/S9

CR/S9

GS9-BAR



Maniglia con rosetta/bocchetta Artax
Lever on Artax rose and key hole

 n. 1 set

GS9-DDN-DX / GS9-DCN-SX

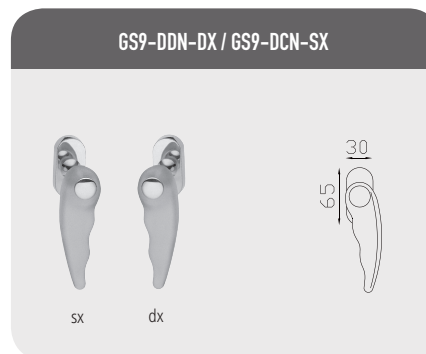

Maniglia con Dreh-Kipp Nika
Lever on Nika Dreh-Kipp

 n. 2 pz

mariani

STYLO

design: Studio Mariani



CS

CR

NS

YEB

Base Material:
Solid Brass - Ottone

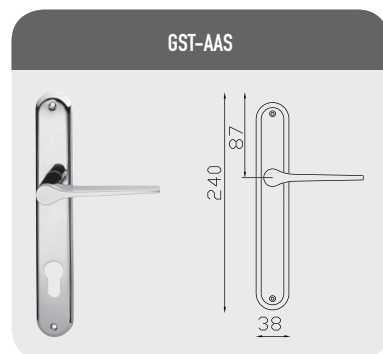

Maniglia con placca Astra
Lever on Astra plate

n. 1 set



Maniglia con rosetta/bocchetta Artax
Lever on Artax rose and key hole

n. 1 set

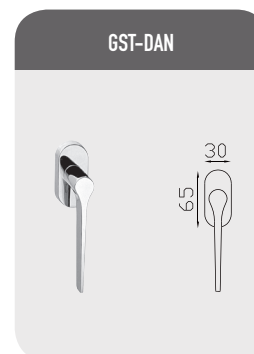

Maniglia con Dreh-Kipp Nika
Lever on Nika Dreh-Kipp

n. 2 pz



Cremonese/Martellina con placca Thalassia C.V.
Movimento non incluso nel prezzo
Cremon/Martellina on Thalassia screw cover plate
Price of mechanism not included

n. 2 pz



mariani

VELA
design: Mauro Ronchi



OLV

CS

CR

Base Material:
Solid Brass - Ottone

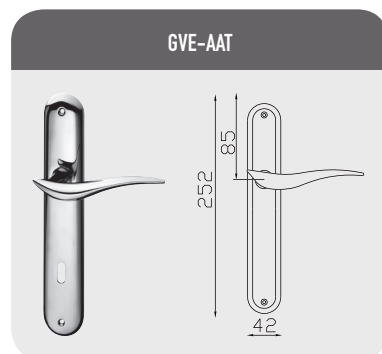

Maniglia con placca Thalassia
Lever on Thalassia plate

n. 1 set



Maniglia con rosetta/bocchetta Artax
Lever on Artax rose and key hole

n. 1 set



Maniglia con Dreh-Kipp Nika
Lever on Nika Dreh-Kipp n. 2 pz

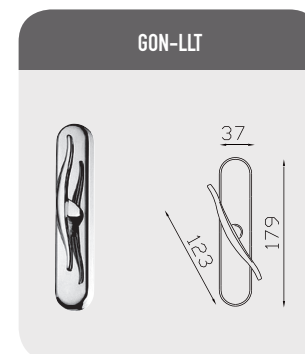

Onda cremonese/Martellina con placca Thalassia C.V.
Movimento non incluso nel prezzo
Onda cremonese/Martellina on Thalassia screw cover plate
Price of mechanism not included

n. 2 pz

mariani

VENTO
design: Studio Mariani



OLV

CS

Base Material:
Solid Brass - Ottone

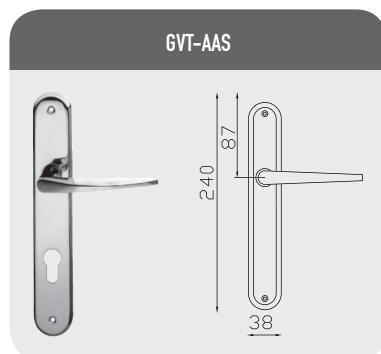

Maniglia con placca Astra
Lever on Astra plate

n. 1 set

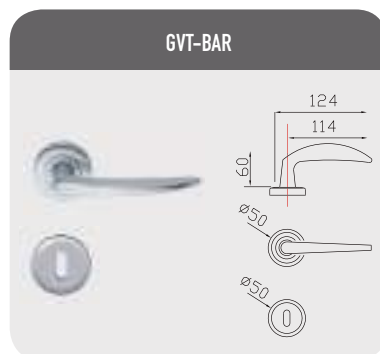

Maniglia con rosetta/bocchetta Artax
Lever on Artax rose and key hole

n. 1 set

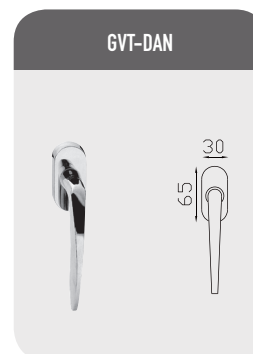

Maniglia con Dreh-Kipp Nika
Lever on Nika Dreh-Kipp

n. 2 pz



Cremonese/Martellina con placca Thalassia C.V.
Movimento non incluso nel prezzo
Cremon/Martellina on Thalassia screw cover plate
Price of mechanism not included

n. 2 pz



mariani

VENUS

design:
Gianfranco Melegari



OLV

CS

YEB

Base Material:
Solid Brass - Ottone

GVS-AAT

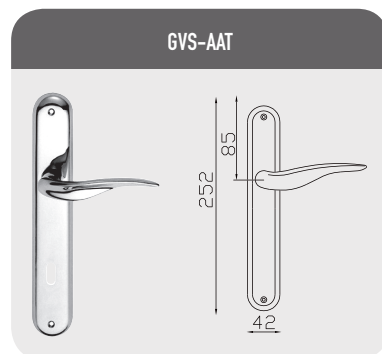

Maniglia con placca Thalassia
Lever on Thalassia plate

 n. 1 set

GVS-BAR



Maniglia con rosetta/bocchetta Artax
Lever on Artax rose and key hole

 n. 1 set

GVS-DDN-DX / GVS-DCN-SX

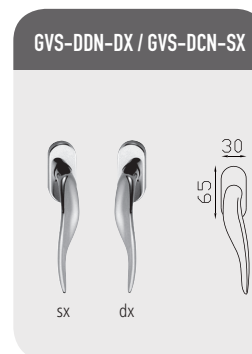

Maniglia con Dreh-Kipp Nika
Lever on Nika Dreh-Kipp  n. 2 pz

GON-LLT



Onda cremonese/Martellina con placca Thalassia C.V.
Movimento non incluso nel prezzo
Onda cremonese/Martellina on Thalassia screw cover plate
Price of mechanism not included

 n. 2 pz

mariani

ZOE

design:
Gianfranco Melegari



OLV

CS

YEB

Base Material:
Solid Brass - Ottone

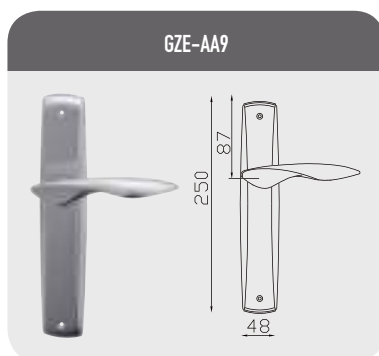

Maniglia con placca Zoe
Lever on Zoe plate

n. 1 set

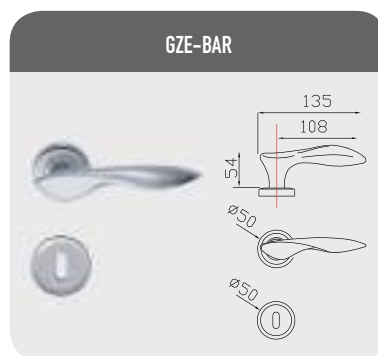

Maniglia con rosetta/bocchetta Artax
Lever on Artax rose and key hole

n. 1 set

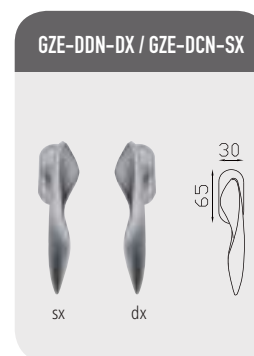

Maniglia con Dreh-Kipp Nika
Lever on Nika Dreh-Kipp n. 2 pz



Kira cremonese/Martellina con placca Thalassia C.V.
Movimento non incluso nel prezzo
Kira cremon/Martellina on Thalassia screw cover plate
Price of mechanism not included

n. 2 pz

SCHEMI PER MANIGLIE CON ROSETTA ARTAX STANDARD ED A RICHIESTA - SCHEMES FOR LEVER ON ARTAX ROSE STANDARD AND ON REQUEST

RO. - Artax - 01 - Standard

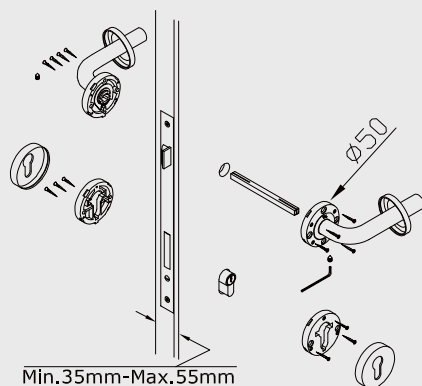

RO. - Artax - 04 - A richiesta - On request

Privacy antipanico
Privacy antipanic

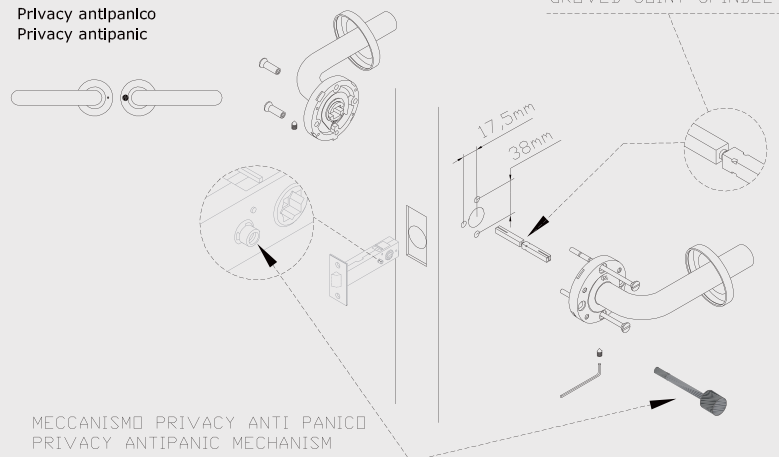

RO. - Artax - 02 - A richiesta - On request

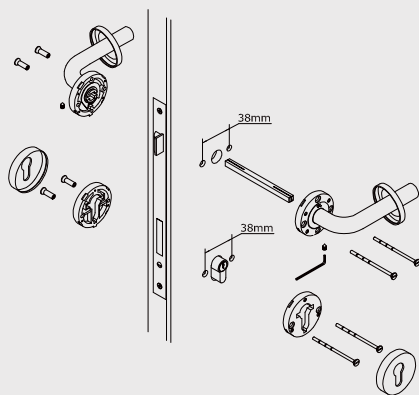

RO. - Artax - 05 - A richiesta - On request

Maniglie su rosetta + bocchetta WC
Lever on rose with turn and release

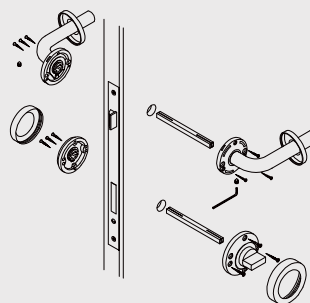

RO. - Artax - 06 - A richiesta - On request

Sistema pomolo esterno fisso e maniglia interna girevole su rosette
System for outside fixed knob and inside working lever and rose

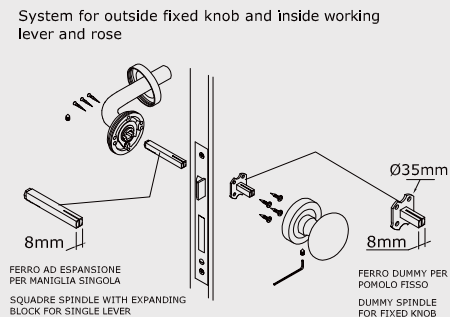

RO. - Artax - 03 - A richiesta - On request

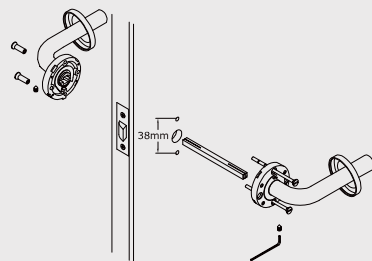

RO. - TP - 07 - A richiesta - On request

Maniglie su rosetta e bocchetta stretta.
Levers on narrow rose and escutcheon

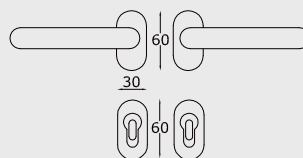

A richiesta - On request

Versione con bussole
Version with bushing

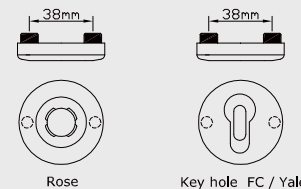

SCHEMI PER MANIGLIE CON PLACCA STANDARD ED A RICHIESTA - SCHEMES FOR LEVER ON ARTAX PLATE STANDARD AND ON REQUEST

PL. - 01 - Standard

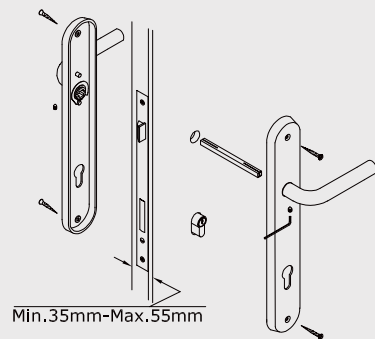

PL. - 02 - A richiesta - On request

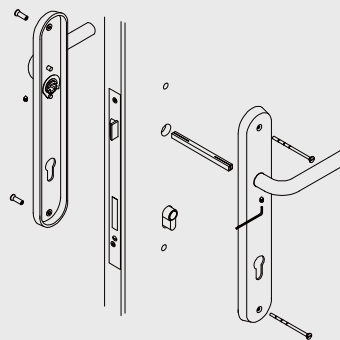

PL. - 03 - A richiesta - On request

Maniglie su placca con sistema WC
Lever on plate with turn and release

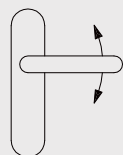
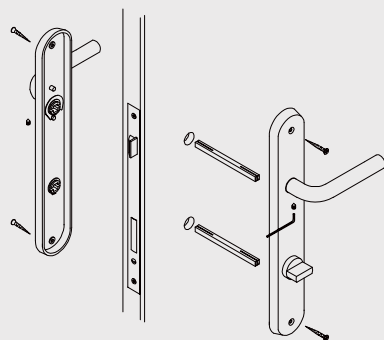

MOLLA AMBIDESTRA PER PLACCA - A RICHIESTA
AMBIDEXTROUS SPRING FOR PLATES - ON REQUEST

PL. - 04 - A richiesta - On request

Sistema pomolo esterno fisso e maniglia Interna
girevole su placche
System for outside fixed knob and inside working
lever and plate

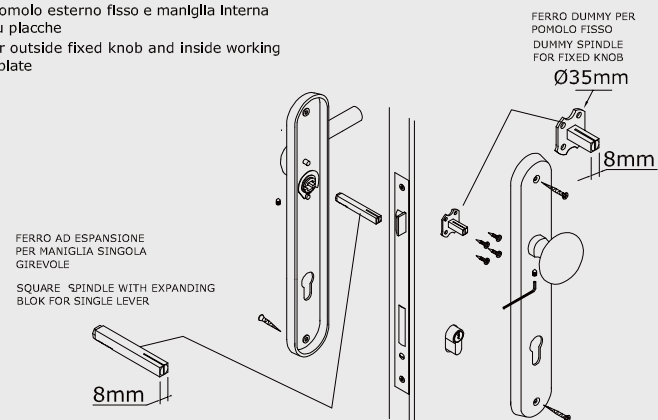

SCHEMI PER MANIGLIERE CON ROSETTA NIKA A RICHIESTA - SCHEMES FOR LEVER ON NIKA ROSES - ON REQUEST

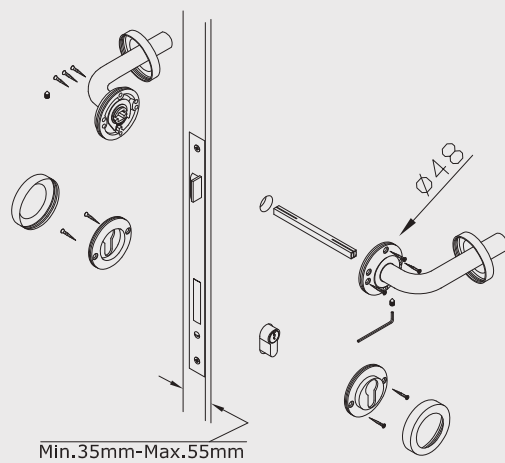

MOLLA AMBIDESTRA PER
ROSETTE NIKA - A RICHIESTA

AMBIDEXTROUS SPRING
FOR NIKA ROSES - ON REQUEST

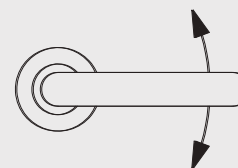

SCHEMA DK - SCHEMES FOR DK

DK - 01 - Standard

DK - 02 - A richiesta - On request

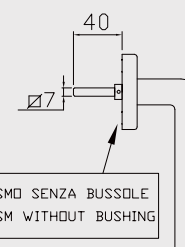
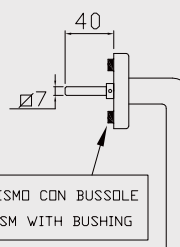
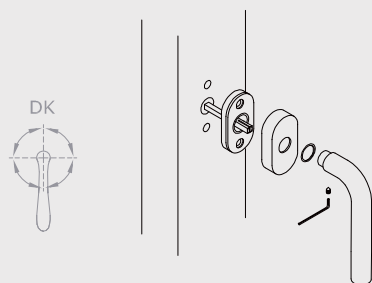

CREMONESI MARTELLINE E MECCANISMI - CREMON MARTELLINE AND MECHANISM

Cremonesi/Martelline con placca coprivite meccanismo jolli a sfilare
 Cremon and Martelline on screw cover plate with extracting

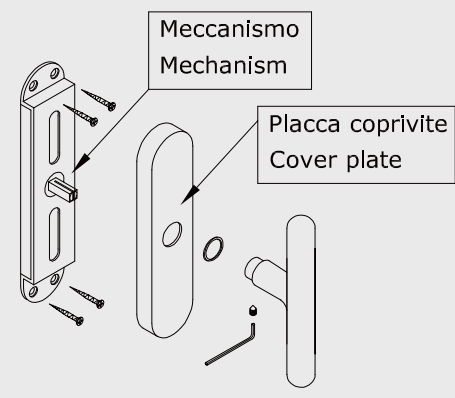

Meccanismi - Mechanism

Mec. Martellina 4F - CCCT - C7

MARTELLINA \varnothing 7X40
 MARTELLINA WITH SPINDLE \varnothing 7X40

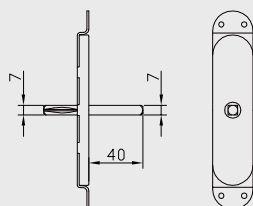

Mec. CREMONESE 4F - CCCC - C7

GRATZ CON BUSSOLE
 GRATZ WITH BUSHES

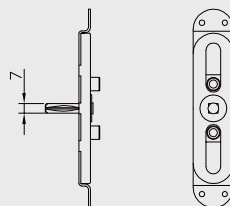

Mec. CREMONESE 4F - CCCC - C7

GRATZ CON BUSSOLE + \varnothing 7X40
 GRATZ WITH BUSHES AND SPINDLE \varnothing 7X40

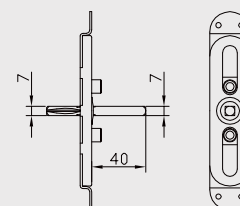

Mec. Cremonese 4F - CCCM - C8

MP CON PERNI
 MP WITH PINS

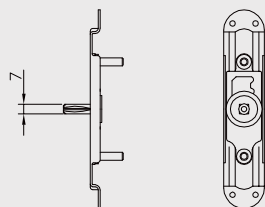

Mec. CREMONESE 4F - CCCE - C7

GRATZ CON PERNI
 GRATZ WITH PINS

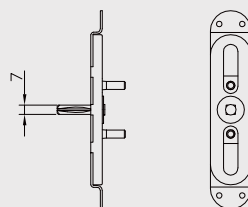

Mec. CREMONESE 4F - CCCE - C8

GRATZ CON PERNI+ \varnothing 7X40
 MGRATZ WITH PINS AND SPINDLE + \varnothing 7X45

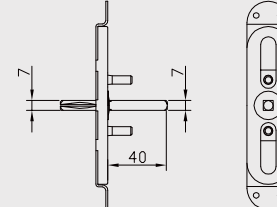

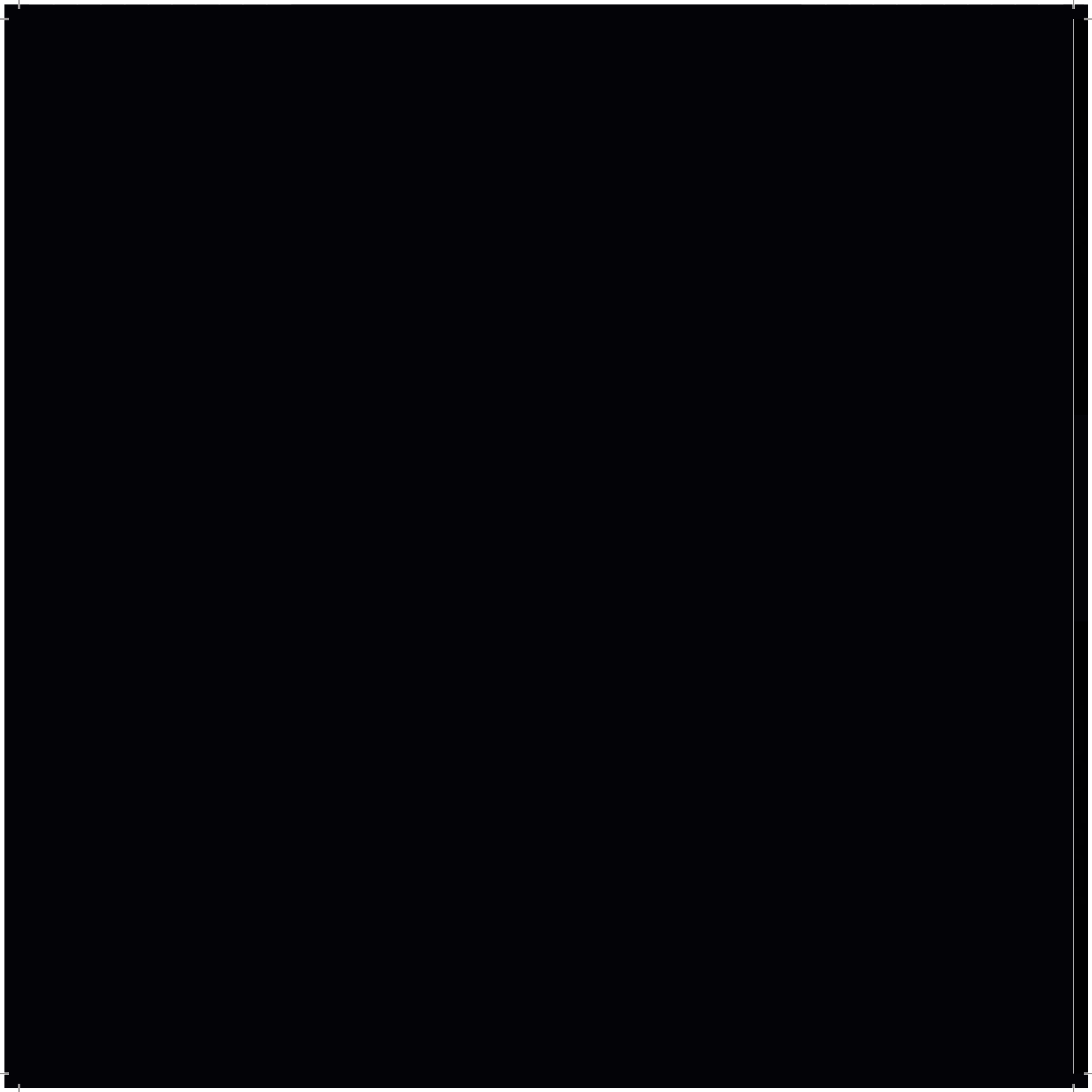

DESIGN MARIANDESIGN MARIANDESIGN
MARIANDESIGN MARIANDESIGN MARIANDESIGN
MARIANDESIGN MARIANDESIGN MARIANDESIGN
DESIGN MARIANDESIGN MARIANDESIGN MARIANDESIGN

MANIGLIE LEVERS



DESIGN MARIANDESIGN MARIANDESIGN MARIANDESIGN
MARIANDESIGN MARIANDESIGN MARIANDESIGN MARIANDESIGN
DESIGN MARIANDESIGN MARIANDESIGN MARIANDESIGN
MARIANDESIGN MARIANDESIGN MARIANDESIGN MARIANDESIGN



mariani

ALICE

design: Studio Mariani



OLV

NLV

Base Material:
Solid Brass - Ottone

GAL-BAI

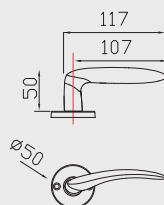

Maniglia con rosetta Historia To. senza bocchetta
Lever on Historia To. rose without escutcheon

 n. 1 set

GAL-BAH

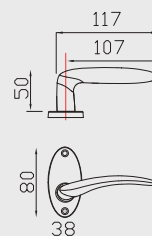

Maniglia con rosetta Historia Ov. senza bocchetta
Lever on Historia Ov. rose without escutcheon

 n. 1 set

mariani

CRYSTAL
design: Studio Mariani



OLV

NLV

Base Material:
Solid Brass - Crystal
Ottone - Cristallo



CRYSTALL

Made with
CRYSTALLIZED™ - Swarovski Elements

GCY-BAI

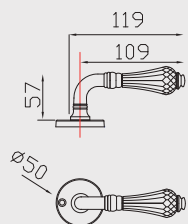

Maniglia con rosetta Historia To. senza bocchetta
Lever on Historia To. rose without escutcheon  n. 1 set

GCY-BAH

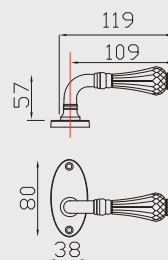

Maniglia con rosetta Historia Ov. senza bocchetta
Lever on Historia Ov. rose without escutcheon  n. 1 set



mariani

EMILY

design: Studio Mariani





OLV

NLV

Base Material:
Solid Brass - Ottone

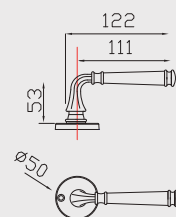
GEY-BAI



Maniglia con rosetta Historia To. senza bocchetta
Lever on Historia To. rose without escutcheon  n. 1 set

GEY-BAH

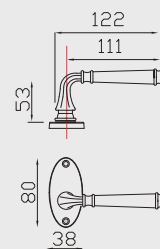

Maniglia con rosetta Historia Ov. senza bocchetta
Lever on Historia Ov. rose without escutcheon  n. 1 set

mariani

FIONA

design: Studio Mariani



OLV

NLV

Base Material:
Solid Brass - Ottone



GFA-BAI

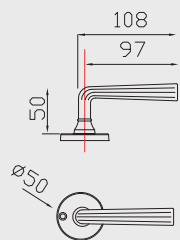

Maniglia con rosetta Historia To. senza bocchetta
Lever on Historia To. rose without escutcheon

n. 1 set

GFA-BAH

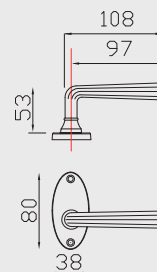

Maniglia con rosetta Historia Ov. senza bocchetta
Lever on Historia Ov. rose without escutcheon

n. 1 set



mariani

FIRENZE EBANO
design: Studio Mariani





OLV

NLV

Base Material:
Solid Brass/Ebony
Ottone/Ebano

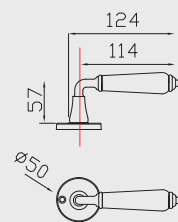
GFB-BAI



Maniglia con rosetta Historia To. senza bocchetta
Lever on Historia To. rose without escutcheon  n. 1 set

GFB-BAH

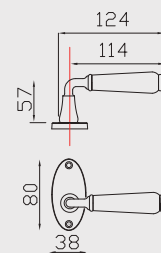

Maniglia con rosetta Historia Ov. senza bocchetta
Lever on Historia Ov. rose without escutcheon  n. 1 set

mariani

GOCCIA
design: Studio Mariani



OLV

NLV

Base Material:
Solid Brass - Ottone



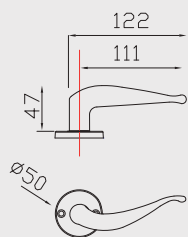

G60-BAI

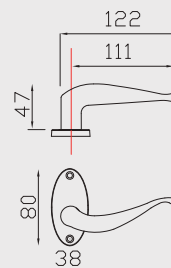

Maniglia con rosetta Historia To. senza bocchetta
Lever on Historia To. rose without escutcheon  n. 1 set

G60-BAH



Maniglia con rosetta Historia Ov. senza bocchetta
Lever on Historia Ov. rose without escutcheon  n. 1 set



mariani

LINEA
design: Studio Mariani





OLV

NLV

Base Material:
Solid Brass - Ottone

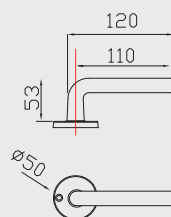
GLE-BAI



Maniglia con rosetta Historia To. senza bocchetta
Lever on Historia To. rose without escutcheon  n. 1 set

GLE-BAH

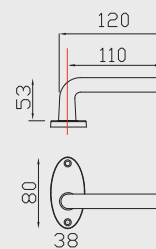

Maniglia con rosetta Historia Ov. senza bocchetta
Lever on Historia Ov. rose without escutcheon  n. 1 set

mariani

LINZ

design: Studio Mariani



OLV

NLV

Base Material:
Solid Brass - Ottone



GLI-BAI

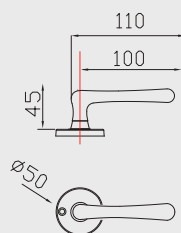

Maniglia con rosetta Historia To. senza bocchetta
Lever on Historia To. rose without escutcheon

n. 1 set

GLI-BAH

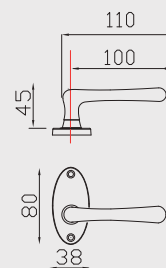

Maniglia con rosetta Historia Ov. senza bocchetta
Lever on Historia Ov. rose without escutcheon

n. 1 set



mariani

ROMA
design: Studio Mariani





OLV

NLV

Base Material:
Solid Brass - Ottone

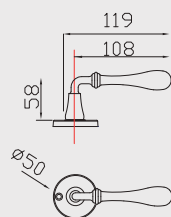
GRM-BAI



Maniglia con rosetta Historia To. senza bocchetta
Lever on Historia To. rose without escutcheon  n. 1 set

GRM-BAH

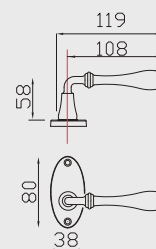

Maniglia con rosetta Historia Ov. senza bocchetta
Lever on Historia Ov. rose without escutcheon  n. 1 set



mariani

SHADOW
design: Studio Mariani



OLV

NLV

Base Material:
Solid Brass - Ottone

GSH-BAI

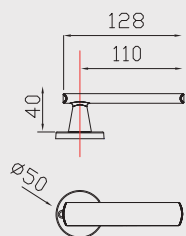

Maniglia con rosetta Historia To. senza bocchetta
Lever on Historia To. rose without escutcheon

 n. 1 set

GSH-BAH

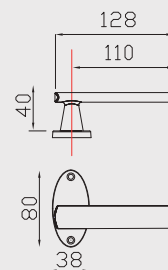

Maniglia con rosetta Historia Ov. senza bocchetta
Lever on Historia Ov. rose without escutcheon

 n. 1 set



mariani

SIENA EBANO
design: Studio Mariani





OLV

NLV

Base Material:
Solid Brass - Ebony
Ottone - Ebano

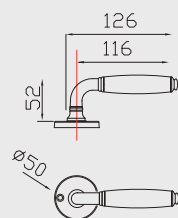
GSB-BAI



Maniglia con rosetta Historia To. senza bocchetta
Lever on Historia To. rose without escutcheon  n. 1 set

GSB-BAH

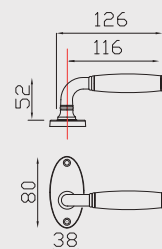

Maniglia con rosetta Historia Ov. senza bocchetta
Lever on Historia Ov. rose without escutcheon  n. 1 set

mariani

STYLO

design: Studio Mariani



OLV

NLV

Base Material:
Solid Brass - Ottone



GST-BAI

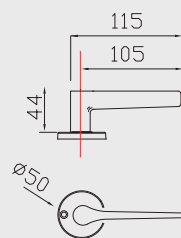

Maniglia con rosetta Historia To. senza bocchetta
Lever on Historia To. rose without escutcheon

n. 1 set

GST-BAH

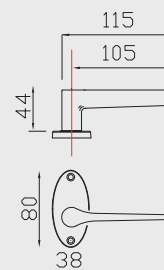

Maniglia con rosetta Historia Ov. senza bocchetta
Lever on Historia Ov. rose without escutcheon

n. 1 set



mariani

VENTO
design: Studio Mariani



OLV

NLV

Base Material:
Solid Brass - Ottone

GVT-BAI

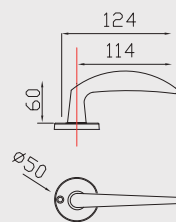

Maniglia con rosetta Historia To. senza bocchetta
Lever on Historia To. rose without escutcheon

 n. 1 set

GVT-BAH

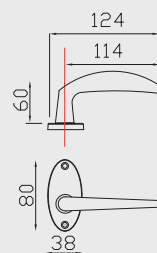

Maniglia con rosetta Historia Ov. senza bocchetta
Lever on Historia Ov. rose without escutcheon

 n. 1 set

mariani

WC

design: Studio Mariani



OLV

NLV

Base Material:
Solid Brass - Ottone



GIT-WAO

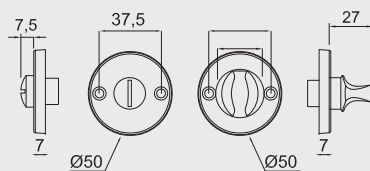

Historia To. bocchetta WC Austria - Historia To.
Escutcheon with Austria bathroom privacy set

n. 5 set

GHV-WAO

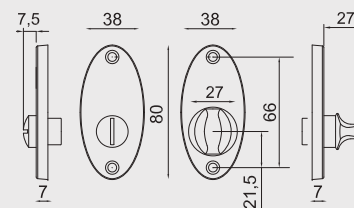

Historia Ov. bocchetta WC Austria - Historia Ov.
Escutcheon with Austria bathroom privacy set

n. 5 set

mariani

ROSETTE
design: Studio Mariani



OLV

NLV

Base Material:
Solid Brass - Ottone



G2A-IT2

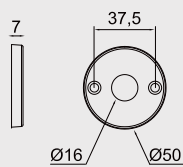

Historia To. Paia Rosette
Historia To. Pair roses

 n. 10 set

G2A-HV2

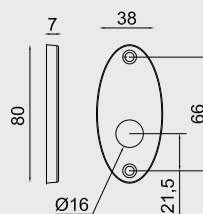

Historia Ov. Paia Rosette
Historia Ov. Pair roses

 n. 10 set

mariani

BOCCHETTE
design: Studio Mariani



OLV

NLV

Base Material:
Solid Brass - Ottone



G2B-IT2

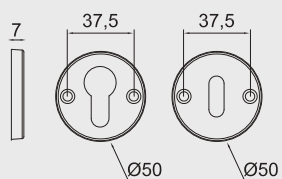

Historia To. paia Bocchette FC/Yale
Historia To. pair key hole PK/Yale

n. 10 set

G2B-HV2

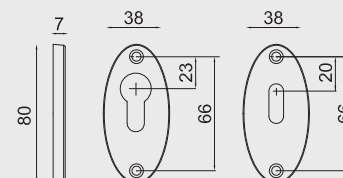

Historia Ov. paia Bocchette FC/Yale
Historia Ov. pair key hole PK/Yale

n. 10 set

SCHEMI PER MANIGLIE CON ROSETTA HISTORIA TO. - SCHEMES FOR LEVER ON HISTORIA TO. ROSE

RO. To. - 01 - Standard

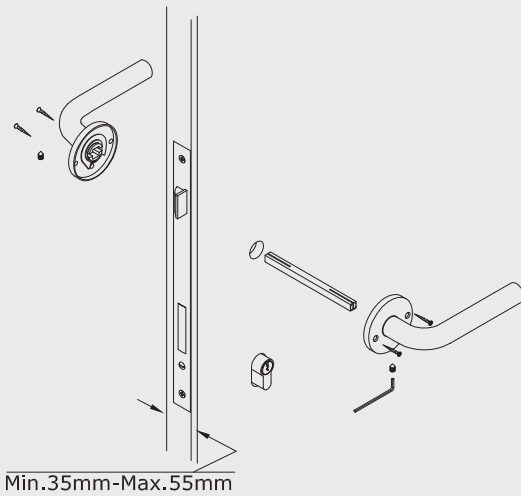

Bocchette - Key holes

RO. To. - 02 - A richiesta - On request

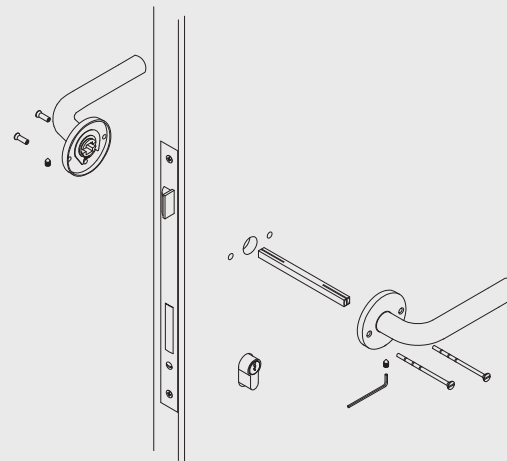

WC

RO. To. - 03

Set. Bocchette Fc./Yale
Set. Rose Fc./Yale

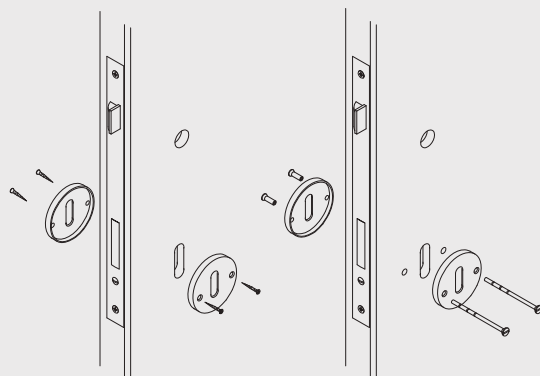

RO. To. - 04

WC. Set.

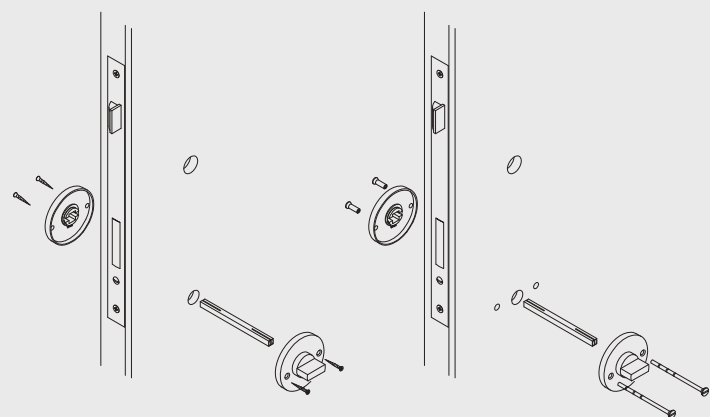

SCHEMI PER MANIGLIE CON ROSETTA HISTORIA OV. - SCHEMES FOR LEVER ON HISTORIA OV. ROSE

RO. Ov. - 01 - Standard

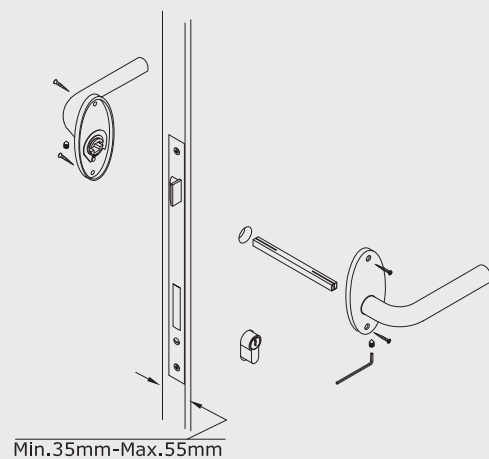

RO. Ov. - 02 - A richiesta - On request

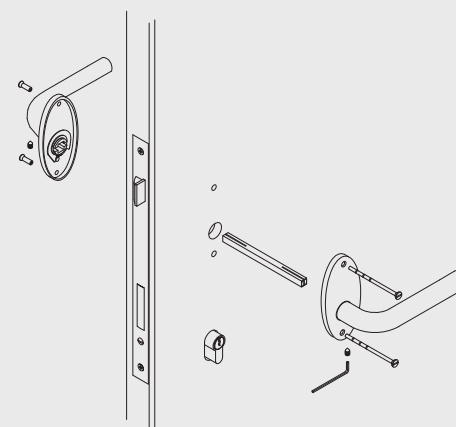

Bocchette - Key holes

RO. Ov. - 03

Set. Bocchette Fc./Yale
Set. Rose Fc./Yale

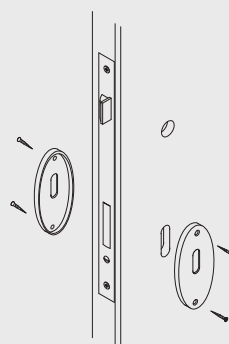

WC

RO. Ov. - 04

WC. Set.

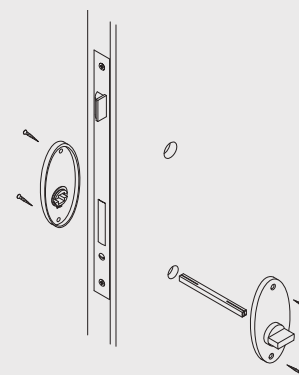

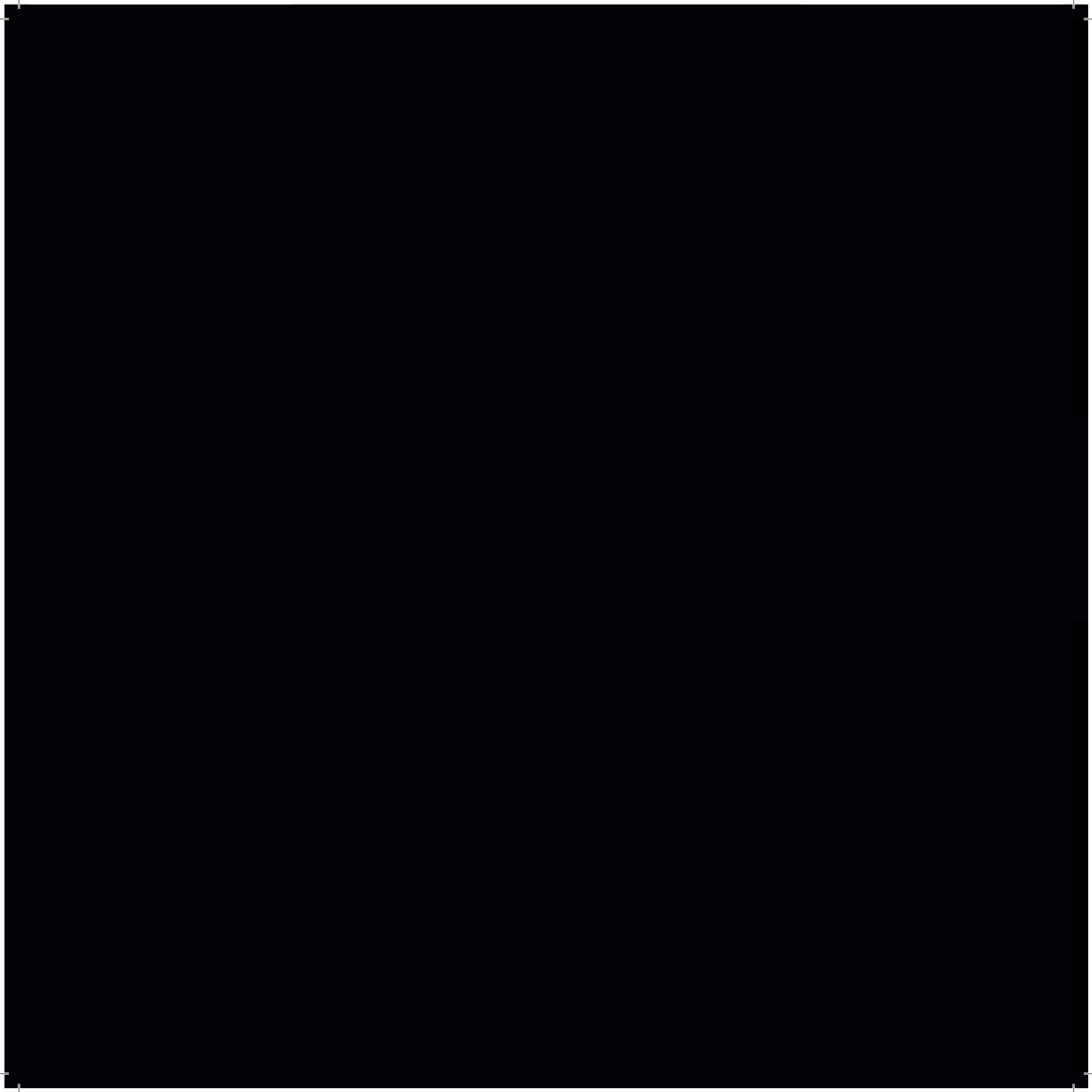

DESIGN MARIANDESIGN MARIANDESIGN
MARIANDESIGN MARIANDESIGN MARIANDESIGN
MARIANDESIGN MARIANDESIGN MARIANDESIGN
DESIGN MARIANDESIGN MARIANDESIGN MARIANDESIGN

MANIGLIE LEVERS



DESIGN MARIANDESIGN MARIANDESIGN MARIANDESIGN
MARIANDESIGN MARIANDESIGN MARIANDESIGN
DESIGN MARIANDESIGN MARIANDESIGN MARIANDESIGN
MARIANDESIGN MARIANDESIGN MARIANDESIGN
MARIANDESIGN MARIANDESIGN



mariani

ALBIOS
design: Studio Mariani



INLS

Base Material:
Stainless Steel - Acciaio Inox

IAB-BAR

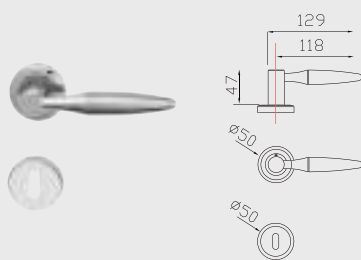

Maniglia con rosetta/bocchetta Artax
Lever on Artax rose and key hole

 n. 1 set

IAB-BAY

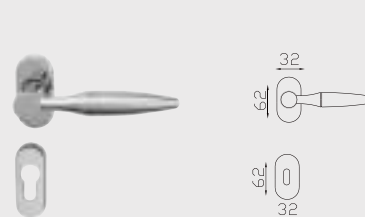

Maniglia con rosetta/bocchetta OP ovale
Lever on OP oval rose and key hole

 n. 1 set

IAB-DAZ



Maniglia con Dreh-Kipp Nika
Lever on Nika Dreh-Kipp

 n. 2 pz



mariani

DRACO
design: Studio Mariani



INLS

Base Material:
Stainless Steel - Acciaio Inox

IDR-BAR

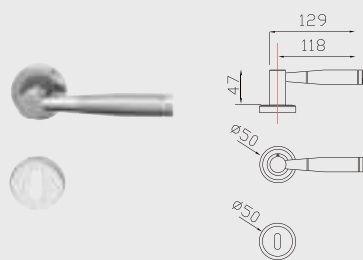

Maniglia con rosetta/bocchetta Artax
Lever on Artax rose and key hole

 n. 1 set

IDR-BAY

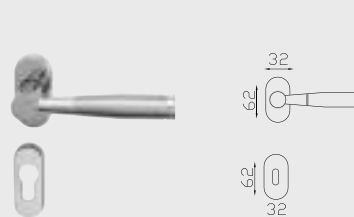

Maniglia con rosetta/bocchetta OP ovale
Lever on OP oval rose and key hole

 n. 1 set

IDR-DAZ

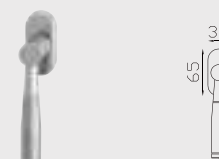

Maniglia con Dreh-Kipp Nika
Lever on Nika Dreh-Kipp

 n. 2 pz



mariani

MEGRES
design: Studio Mariani



INLS

Base Material:
Stainless Steel - Acciaio Inox

IMG-BAR

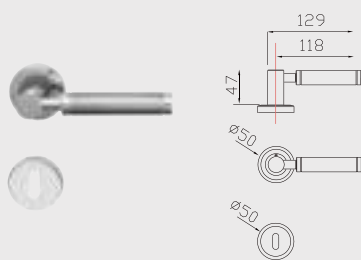

Maniglia con rosetta/bocchetta Artax
Lever on Artax rose and key hole

 n. 1 set

IMG-BAY

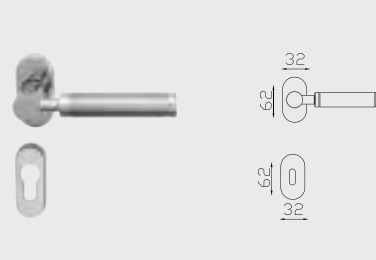

Maniglia con rosetta/bocchetta OP ovale
Lever on OP oval rose and key hole

 n. 1 set

IMG-DAZ

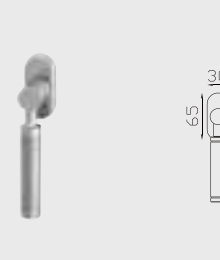

Maniglia con Dreh-Kipp Nika
Lever on Nika Dreh-Kipp

 n. 2 pz

IMG-JCA

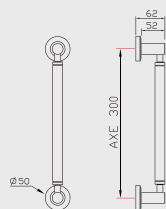

Maniglione axe mm300 con rosetta Artax
Pull Handle axe mm300 on Artax rose  n. 1 pz

IMG-JCB

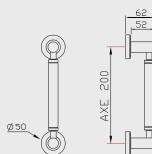

Maniglione axe mm200 con rosetta Artax
Pull Handle axe mm200 on Artax rose  n. 1 pz

KIT FISSAGGIO-FIXING KIT

G1H-TD0

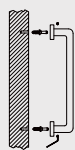

G1H-TP0

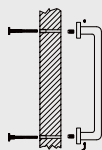

G1H-TA0

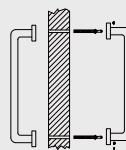

Kit di fissaggio a richiesta non incluso nel prezzo
Fixing kit not included in the price



mariani

MEGRES
MANIGLIONE
design: Studio Mariani



INLS

Base Material:
Stainless Steel - Acciaio Inox

SCHEMI PER MANIGLIE CON ROSETTA ARTAX INOX STANDARD ED A RICHIESTA - SCHEMES FOR LEVER ON ARTAX ROSE STAINLESS STEEL STANDARD AND ON REQUEST

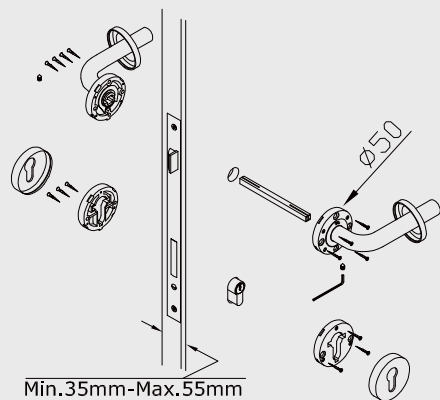

RO. - Artax.Inox - 02 - A richiesta - On request

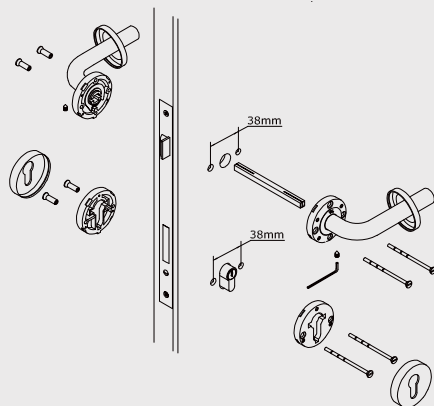

RO. - Artax.Inox - 03 - A richiesta - On request

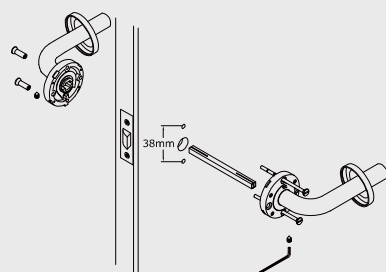

RO. - Artax.Inox - 04 - A richiesta - On request

Privacy antipanico
Privacy antipanic

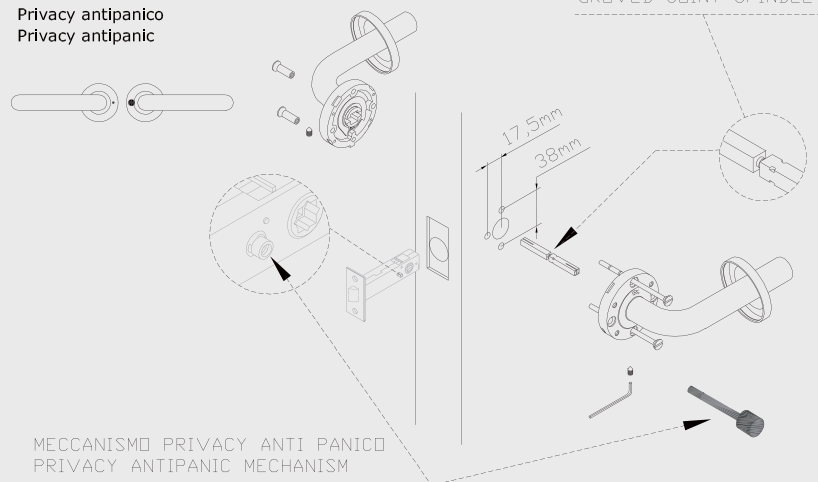

RO. - TP.Inox 07 - A richiesta - On request

Maniglie su rosetta e bocchetta stretta
Levers on narrow rose and escutcheon

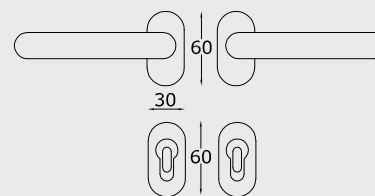

A richiesta - On request

Versione con bussole
Version with bushing

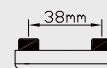

Rose

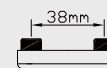

Key hole FC / Yale

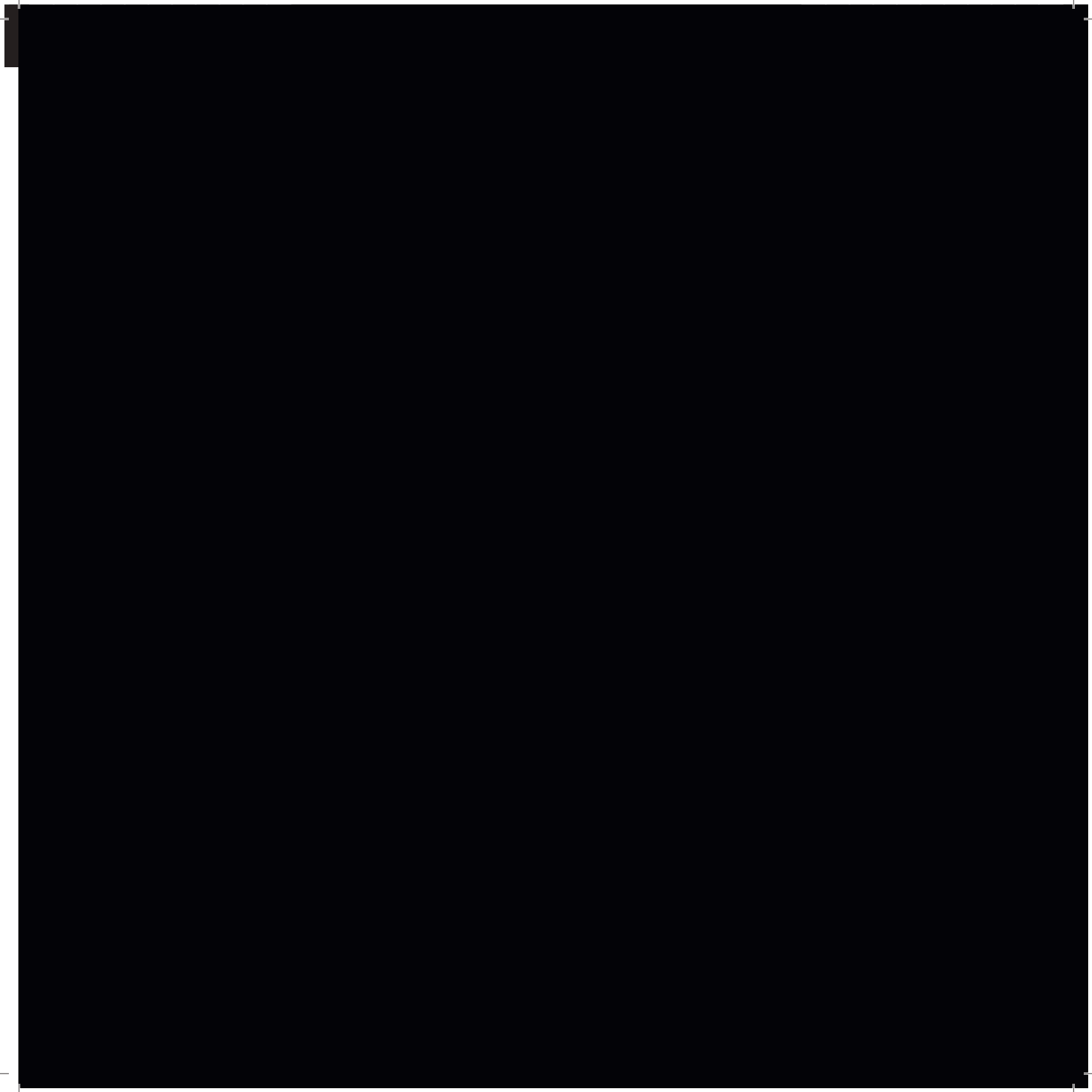

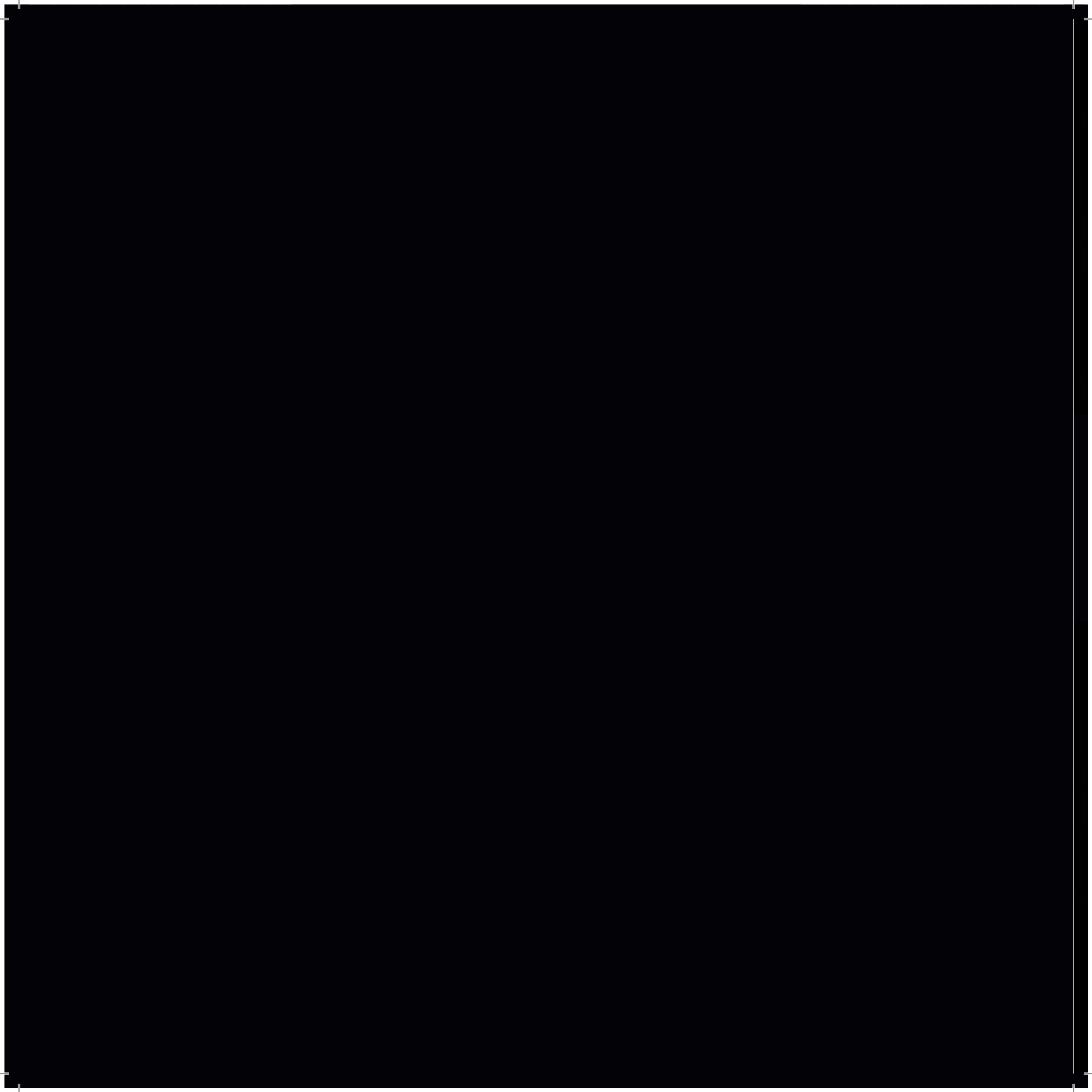

DESIGN MARIANDESIGN MARIANDESIGN
SIGN MARIANDESIGN MARIANDESIGN MARIANDESIGN
RIANDESIGN MARIANDESIGN MARIANDESIGN
SIGN MARIANDESIGN MARIANDESIGN MARIANDESIGN

MANIGLIONI
PULL HANDLES

DESIGN MARIANDESIGN MARIANDESIGN MARIANDESIGN
RIANDESIGN MARIANDESIGN MARIANDESIGN
SIGN MARIANDESIGN MARIANDESIGN MARIANDESIGN
RIANDESIGN MARIANDESIGN MARIANDESIGN
RIANDESIGN MARIANDESIGN

mariani

EGLE

OLV

CS

Base Material:
Solid Brass - Ottone

**ELIMINATO
NO MORE AVAILABLE**



GEG-JSN

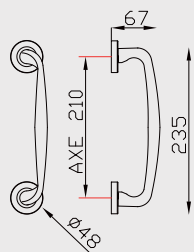

Maniglione axe mm210 con rosetta Nika
Pull Handle axe mm210 on Nika rose  n. 1 pz

KIT FISSAGGIO-FIXING KIT

G1H-TD0

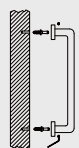

G1H-TP0

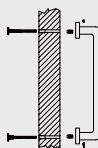

G1H-TA0

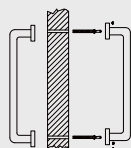

Kit di fissaggio a richiesta non incluso nel prezzo
Fixing kit not included in the price

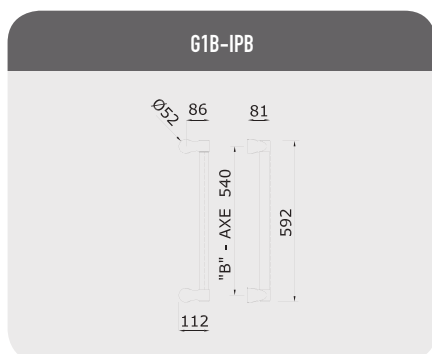

Maniglione axe mm540
Pull Handle axe mm540

 n. 1 pz

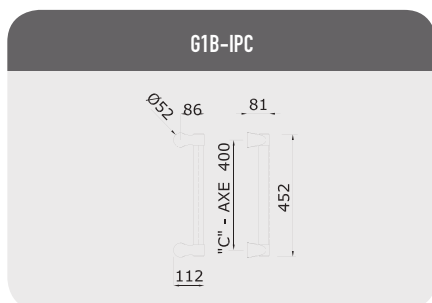

Maniglione axe mm400
Pull Handle axe mm400

 n. 1 pz

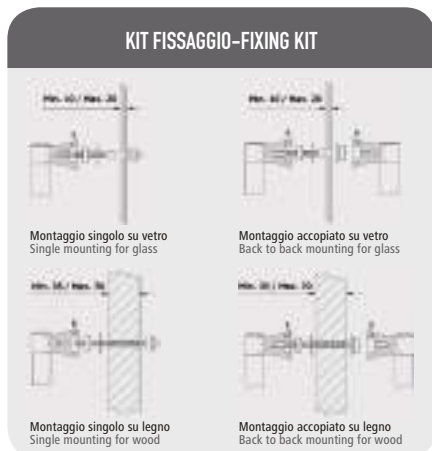

Kit fissaggio incluso nel prezzo
Fixing kit included in the price



mariani

ITALY LEATHER

design: Studio Mariani

OLV

CS

Base Material:
Solid Brass /Leather
Ottone/Cuoio

Maniglione con
impugnatura
ricoperta in cuoio
Pull handle with
leather cover

G1B-IYA



Maniglione axe mm758
Pull Handle axe mm758

 n. 1 pz

G1B-IYB



Maniglione axe mm540
Pull Handle axe mm540

 n.1 pz

G1B-IYC

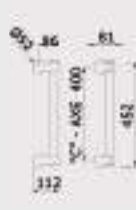

Maniglione axe mm400
Pull Handle axe mm400

 n.1 pz

KIT FISSAGGIO-FIXING KIT



Montaggio singolo su vetro
Single mounting for glass

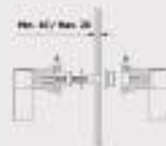

Montaggio accoppiato su vetro
Back to back mounting for glass



Montaggio singolo su legno
Single mounting for wood



Montaggio accoppiato su legno
Back to back mounting for wood

Kit fissaggio incluso nel prezzo
Fixing kit included in the price



mariani

ITALY
design: Studio Mariani

OLV

CS

Base Material:
Solid Brass - Ottone

mariani

ITALY CURVO

design: Studio Mariani

OLV

CS

Base Material:
Solid Brass - Ottone



G1B-IXO



Maniglione axe mm378
Pull Handle axe mm378

 n. 1 pz

KIT FISSAGGIO-FIXING KIT



Montaggio singolo su vetro
Single mounting for glass

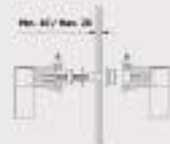

Montaggio accoppiato su vetro
Back to back mounting for glass



Montaggio singolo su legno
Single mounting for wood



Montaggio accoppiato su legno
Back to back mounting for wood

Kit fissaggio incluso nel prezzo
Fixing kit included in the price

mariani

ITALY ESSE

design: Studio Mariani

OLV

CS

Base Material:
Solid Brass - Ottone



G1B-IS0

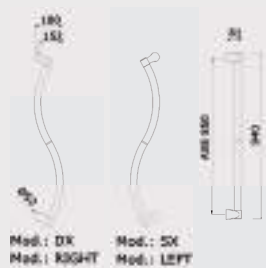

Maniglione axe mm850
Pull Handle axe mm850

 n. 1 pz

KIT FISSAGGIO-FIXING KIT

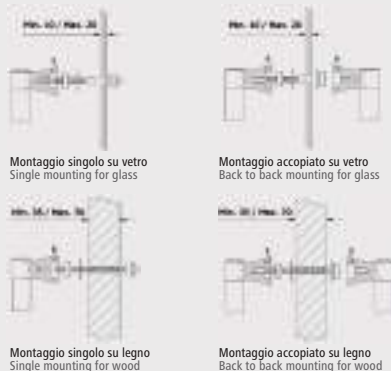

Kit fissaggio incluso nel prezzo
Fixing kit included in the price

mariani

KIRA

design: Studio Mariani

OLV

CS

Base Material:
Solid Brass - Ottone

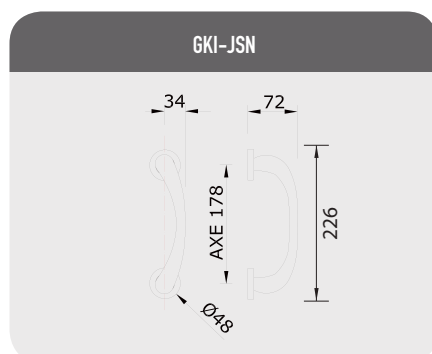

Maniglione axe mm178 con rosetta Nika
Pull Handle axe mm178 on Nika rose

 n. 1 pz

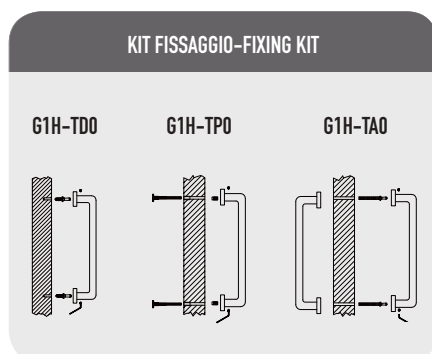

Kit di fissaggio a richiesta non incluso nel prezzo
Fixing kit not included in the price

mariani[®]**ONDA**
design: Mauro Ronchi

OLV

CS

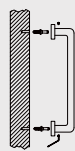
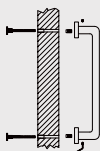
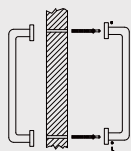
Base Material:
Solid Brass - Ottone**GON-JSN**Maniglione axe mm178 con rosetta Nika
Pull Handle axe mm178 on Nika rose
 n. 1 pz
KIT FISSAGGIO-FIXING KIT**61H-TD0****61H-TP0****61H-TA0**Kit di fissaggio non incluso nel prezzo
Fixing kit not included in the price

61B-ORA

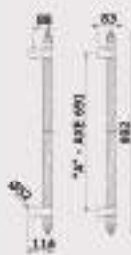

Maniglione axe mm691
Pull Handle axe mm691

 n. 1 pz

61B-ORB



Maniglione axe mm547
Pull Handle axe mm547

 n.1 pz

61B-ORC

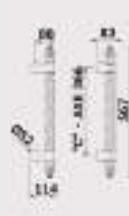

Maniglione axe mm366
Pull Handle axe mm366

 n.1 pz

KIT FISSAGGIO-FIXING KIT



Montaggio singolo su vetro
Single mounting for glass

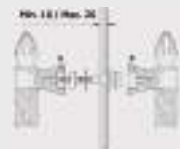

Montaggio accoppiato su vetro
Back to back mounting for glass

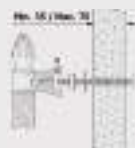

Montaggio singolo su legno
Single mounting for wood

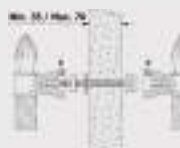

Montaggio accoppiato su legno
Back to back mounting for wood

Kit fissaggio incluso nel prezzo
Fixing kit included in the price



mariani

ORIENT
design: Studio Mariani

OLV

CS

YEB

Base Material:
Solid Brass - Ottone

mariani

Qbe

design: Studio Mariani

CS

CR

NS

Base Material:
Solid Brass - Ottone



GOB-JCD

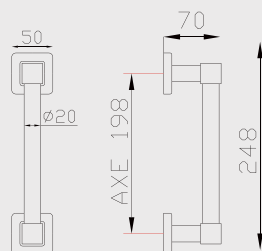

Maniglione con rosetta Qbe
Pull Handle on Qbe rose

 n. 1 pz

KIT FISSAGGIO-FIXING KIT

G1H-TD0

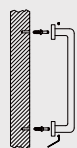

G1H-TP0

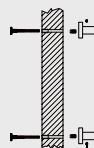

G1H-TA0

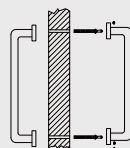

Kit di fissaggio a richiesta non incluso nel prezzo
Fixing kit not included in the price

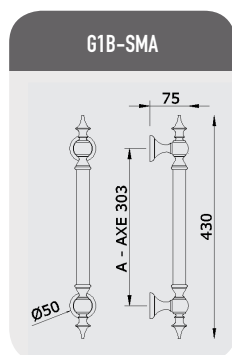

Maniglione axe mm303
Pull Handle axe mm303 n.1 pz

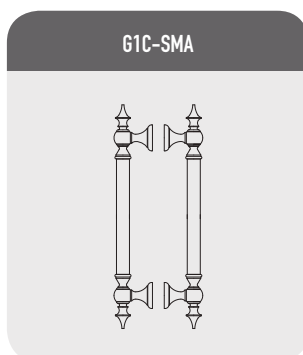

Maniglione axe mm303 accoppiato
Pull handles axe mm303 back to back n.1 pz

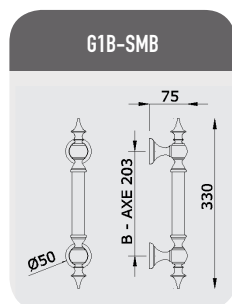

Maniglione axe mm203
Pull Handle axe mm203 n.1 pz

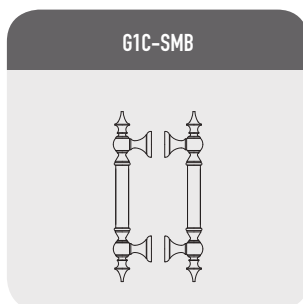

Maniglione axe mm203 accoppiato
Pull handles axe mm203 back to back n.1 pz

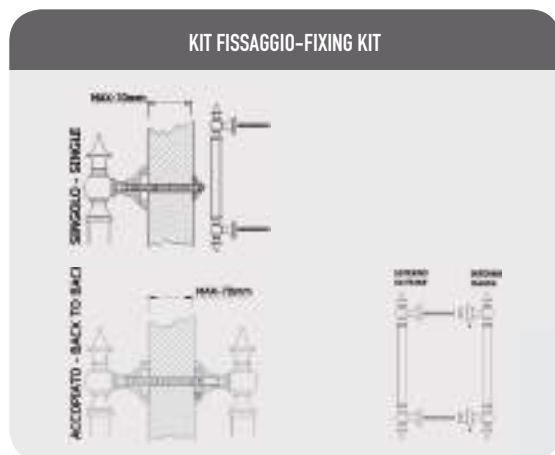

Kit fissaggio incluso nel prezzo
Fixing kit included in the price

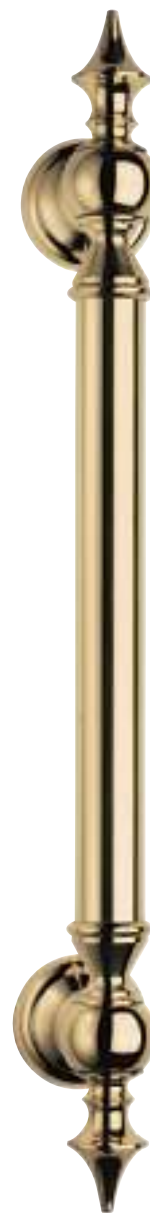

mariani

SMERALDO

design: Studio Mariani

OLV

YEB

Base Material:
Solid Brass - Ottone

61B-SLA

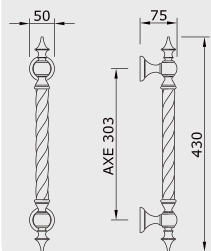

Maniglione axe mm303
Pull Handle axe mm303 n.1 pz

61C-SLA

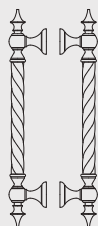

Maniglione axe mm303 accoppiato
Pull handle axe mm303 back to back n.1 pz

61B-SLB

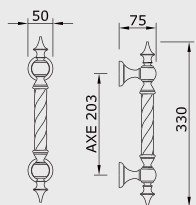

Maniglione axe mm203
Pull Handle axe mm203 n.1 pz

61C-SLB

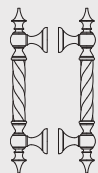

Maniglione axe mm203 accoppiato
Pull handle axe mm203 back to back n.1 pz

KIT FISSAGGIO-FIXING KIT

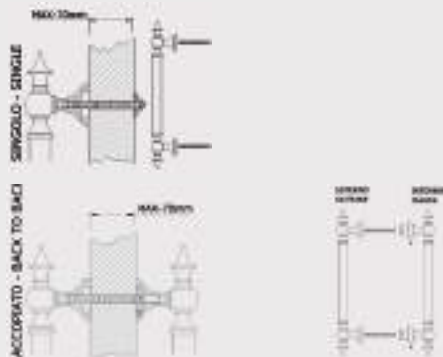

Kit fissaggio incluso nel prezzo
Fixing kit included in the price



mariani
**SMERALDO
TORCIGLIONE**

design: Studio Mariani

OLV

YEB

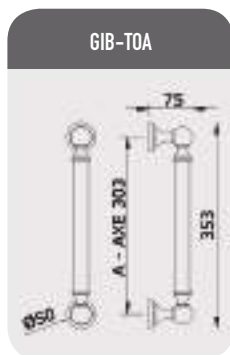
 Base Material:
Solid Brass - Ottone



Maniglione axe mm303
Pull Handle axe mm303 n.1 pz

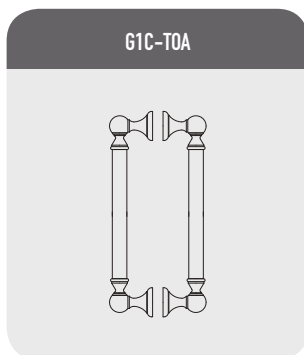

Maniglione axe mm303 accoppiato
Pull handle axe mm303 back to back n.1 pz

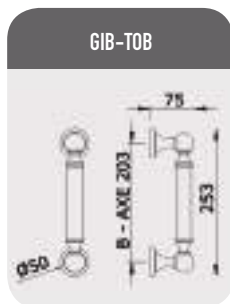

Maniglione axe mm203
Pull Handle axe mm203 n.1 pz

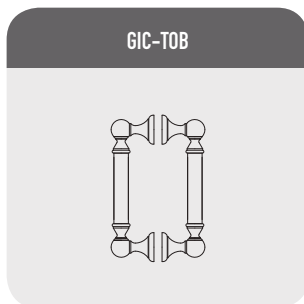

Maniglione axe mm203 accoppiato
Pull handle axe mm203 back to back n.1 pz

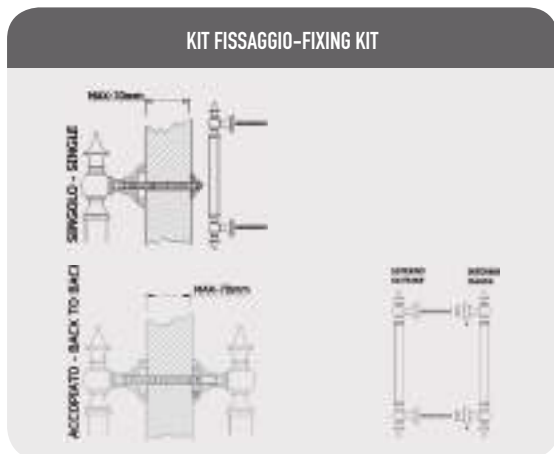

Kit fissaggio incluso nel prezzo
Fixing kit included in the price



mariani

TOPAZIO

design: Studio Mariani

OLV

YEB

Base Material:
Solid Brass - Ottone

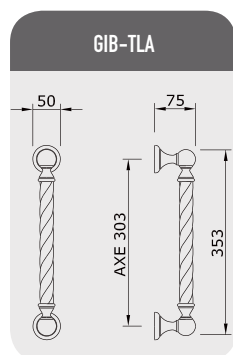

Maniglione axe mm303
Pull Handle axe mm303 n.1 pz

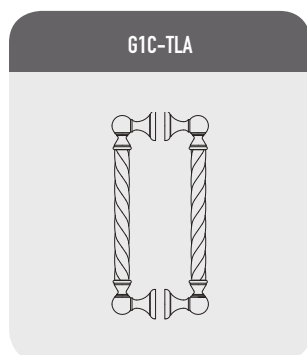

Maniglione axe mm303 accoppiato
Pull handles axe mm303 back to back n.1 pz

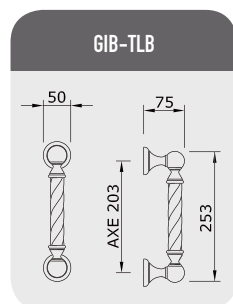

Maniglione axe mm203
Pull Handle axe mm203 n.1 pz

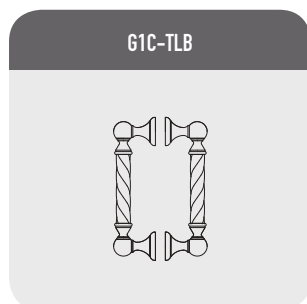

Maniglione axe mm203 accoppiato
Pull handles axe mm203 back to back n.1 pz

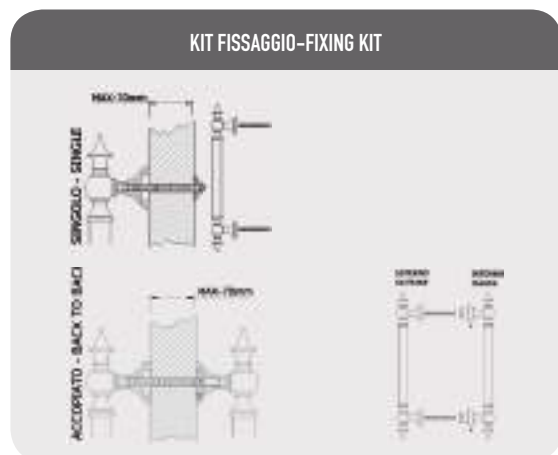

Kit fissaggio incluso nel prezzo
Fixing kit included in the price



mariani

**TOPAZIO
TORCIGLIONE**
design: Studio Mariani

OLV

YEB

Base Material:
Solid Brass - Ottone

mariani

VENUS

design:
Gianfranco Melegari

OLV

CS

YEB

Base Material:
Solid Brass - Ottone



GVS-JS0

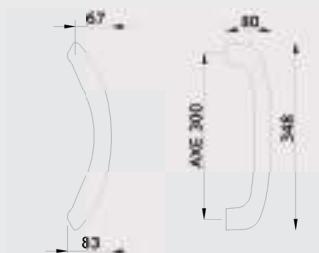

Maniglione axe mm300
Pull Handle axe mm300

 n. 1 pz

KIT FISSAGGIO-FIXING KIT

G1H-TD0

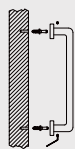

G1H-TP0

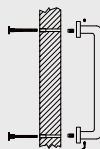

G1H-TA0

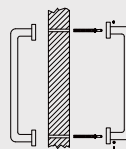

Kit di fissaggio non incluso nel prezzo
Fixing kit not included in the price

mariani

ZANTE
design:
Gianfranco Melegari

OLV

CS

YEB

Base Material:
Solid Brass - Ottone



GZN-JSO

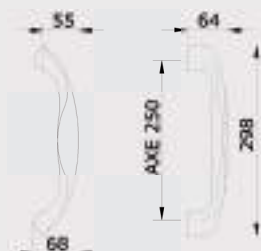

Maniglione axe mm250
Pull Handle axe mm250

 n. 1 pz

KIT FISSAGGIO - FIXING KIT

G1H-TD0

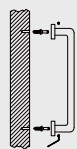

G1H-TP0

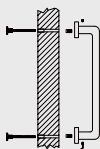

G1H-TA0

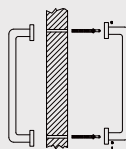

Kit di fissaggio non incluso nel prezzo
Fixing kit not included in the price

KIT FISSAGGIO MANIGLIONI - FIXING KIT FOR PULL HANDLES

1H-TD0

Kit fissaggio maniglione singolo sistema Dummy per porte in legno
Fixing kit for single pull handle Dummy system for wooden doors

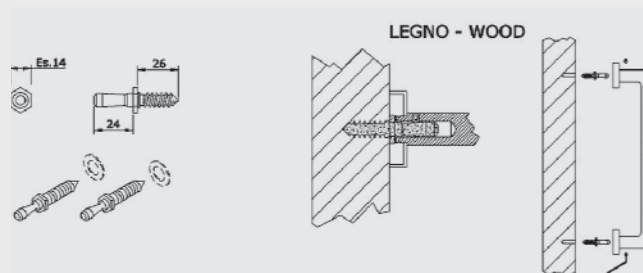
**1H-TPO**

Kit fissaggio maniglione singolo con vite passante
Bolt through mounting for single pull handles

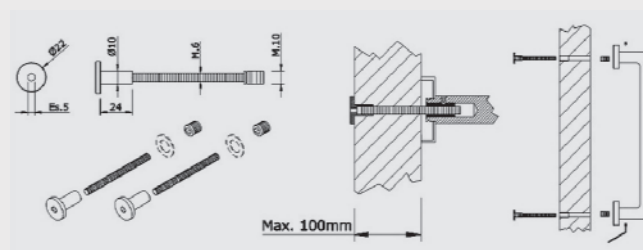
**Finiture**

OLV - CR - CS - YEB - SIB

1H-TA0

Kit fissaggio maniglione accoppiato per porte in legno e vetro
Mounting kit pull handles back to back on glass or wooden door

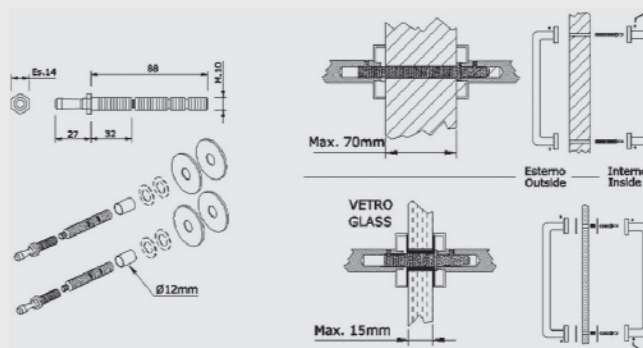

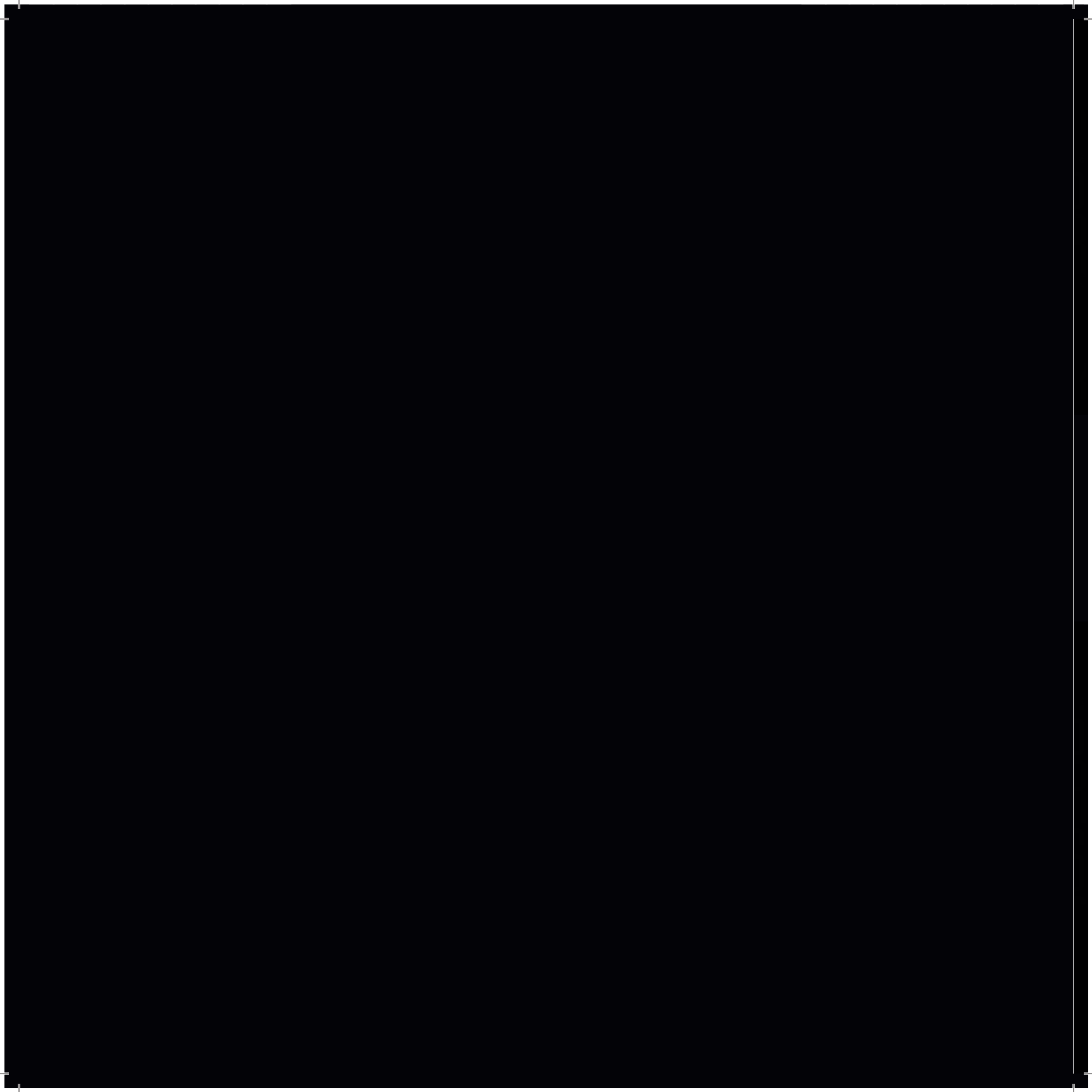

DESIGN MARIANDESIGN MARIANDESIGN
DESIGN MARIANDESIGN MARIANDESIGN
DESIGN MARIANDESIGN MARIANDESIGN
DESIGN MARIANDESIGN MARIANDESIGN

POMOLI
KNOBS

DESIGN MARIANDESIGN MARIANDESIGN
DESIGN MARIANDESIGN MARIANDESIGN
DESIGN MARIANDESIGN MARIANDESIGN
DESIGN MARIANDESIGN MARIANDESIGN

mariani**ASTRA**
design: Studio Mariani

OLV

CS

Base Material:
Solid Brass - Ottone

GAS-FAI

**A**Pomolo fisso singolo
Single fixed knob
 n. 1 pz

GAS-FBR

**B**Pomolo fisso singolo con rosetta Artax
Single fixed knob on Artax rose
 n. 1 pz

GAS-GAR

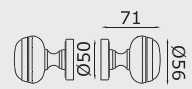
**B**Set Pomoli girevoli con rosetta Artax
Knobset on Artax rose
 n. 1 set

mariani

IRIS

design: Studio Mariani

OLV

CS

Base Material:
Solid Brass - Ottone



GIR-FAI



A

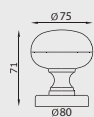

Pomolo fisso singolo
Single fixed knob

 n. 1 pz

GIR-FBR



B

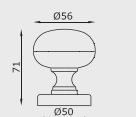

Pomolo fisso singolo con rosetta Artax
Single fixed knob on Artax rose

 n. 1 pz

GIR-GAR



B

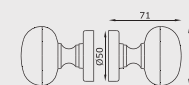

Set Pomoli girevoli con rosetta Artax
Knobset on Artax rose

 n. 1 set

mariani**QBE**

design: Studio Mariani

OLV

CS

Base Material:
Solid Brass - Ottone

GQB-FBD

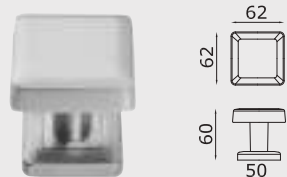

Pomolo fisso singolo con rosetta Qbe
Single fixed knob on Qbe rose

 n. 1 pz

GQB-GAD



Set Pomoli girevoli con rosetta Qbe
Knobset on Qbe rose

 n. 1 set

mariani

SFERA

design: Studio Mariani

OLV

CS

Base Material:
Solid Brass - Ottone



GSF-FAI

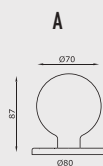

Pomolo fisso singolo
Single fixed knob

n. 1 pz

GSF-FBR



Pomolo fisso singolo con rosetta Artax
Single fixed knob on Artax rose

n. 1 pz

GSF-GAR

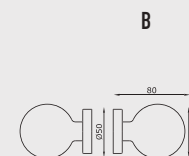

Set Pomoli girevoli con rosetta Artax
Knobset on Artax rose

n. 1 set

POMOLI SCHEMI DI MONTAGGIO - KNOBS MOUNTING EXAMPLES

Montaggio pomolo singolo fisso tipo A/B con vite passante
Mounting for fixed knob tipe A/B through screw

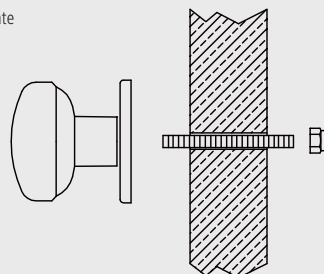

Montaggio pomolo fisso singolo tipo A/B con ferro dummy - **A RICHIESTA**
Mounting for fixed knob tipe A/B with dummy spindle - **ON DEMAND**

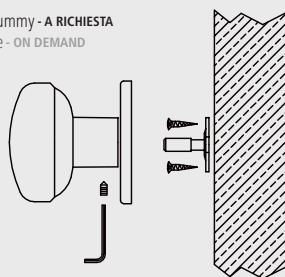

Montaggio pomoli accoppiati girevoli tipo B
Mounting for knobset B

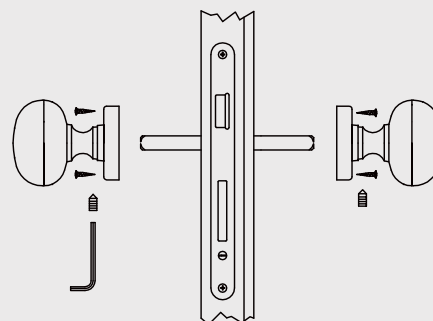

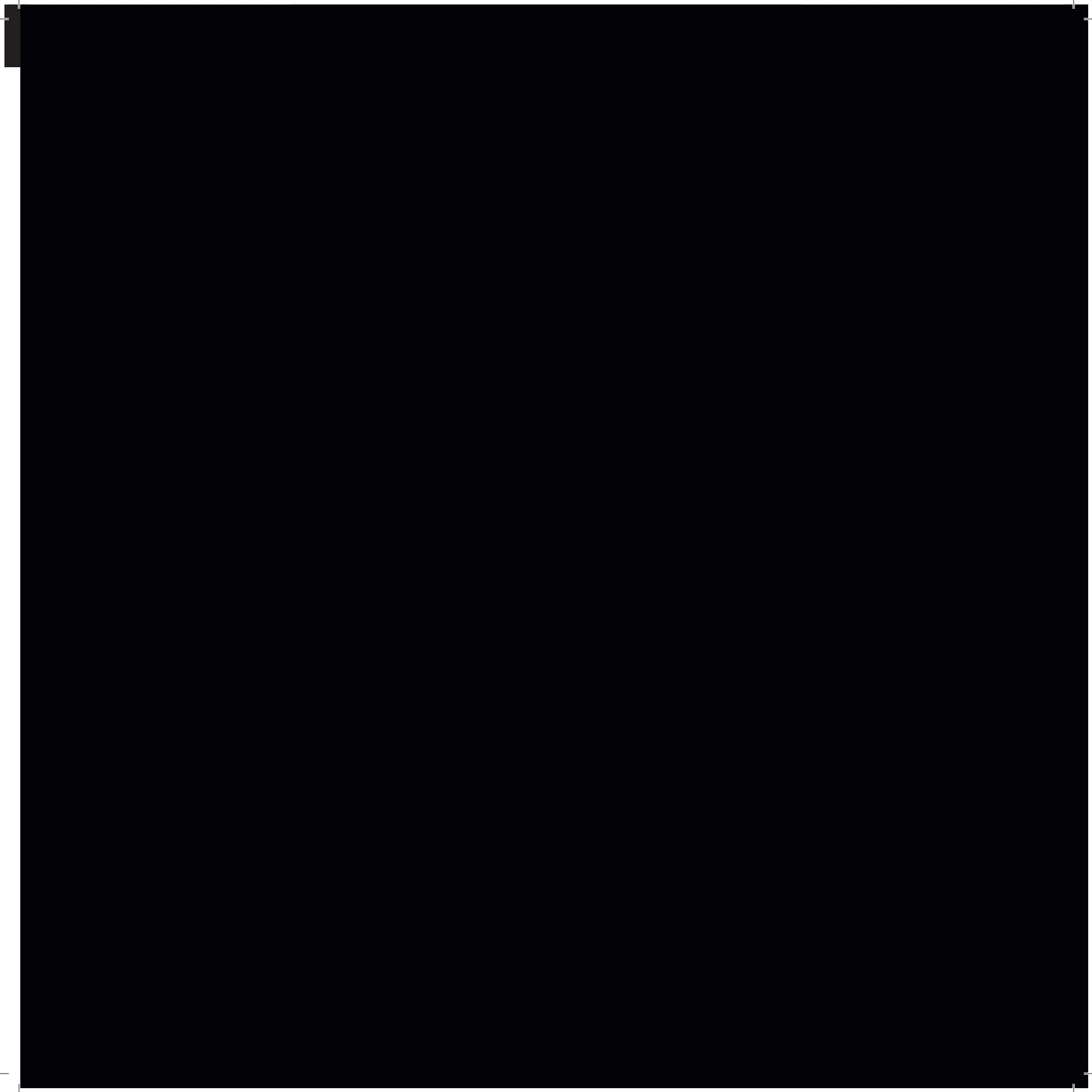

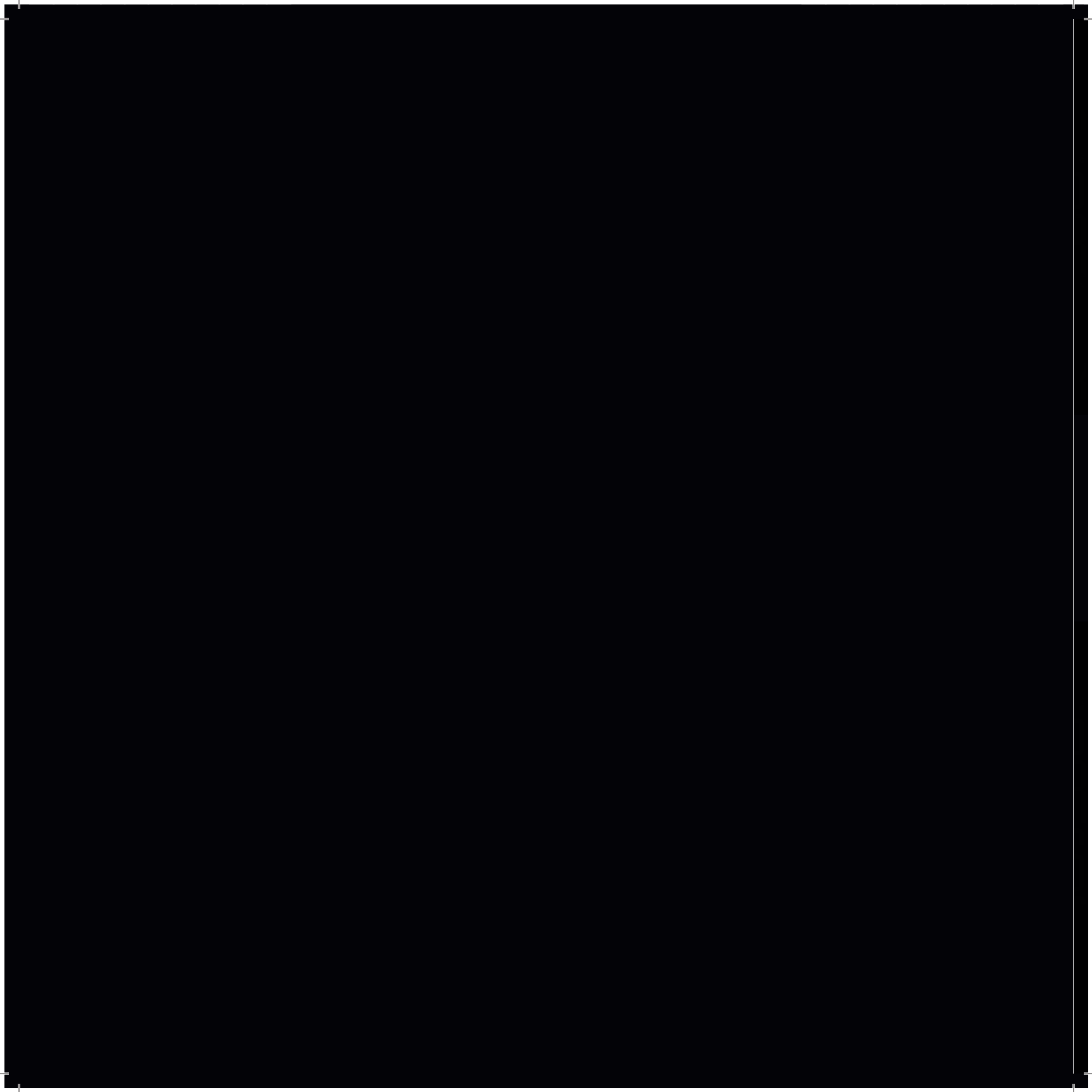

DESIGN MARIANIDESIGN MARIANIDESIGN
SIGN MARIANIDESIGN MARIANIDESIGN MARIAN
RIANIDESIGN MARIANIDESIGN MARIANIDESIGN
SIGN MARIANIDESIGN MARIANIDESIGN MARIAN

BUCA LETTERE

LETTER PLATES

DESIGN MARIANIDESIGN MARIANIDESIGN MARIAN
RIANIDESIGN MARIANIDESIGN MARIANIDESIGN
SIGN MARIANIDESIGN MARIANIDESIGN MARIAN
RIANIDESIGN MARIANIDESIGN MARIANIDESIGN
SIGN MARIANIDESIGN MARIANIDESIGN

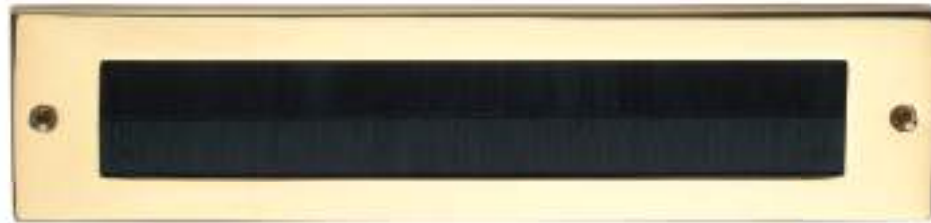

mariani

ELLENALENA
design: Studio Mariani

OLV

CS

Base Material:
Solid Brass - Ottone

G3T-ELO

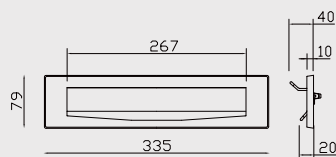

Ellen bucalettere esterno
Ellen external letter plate

 n. 1 pz

G3T-ALO



Alena bucalettere interno
Alena internal letter plate

 n. 1 pz

mariani

HANS/ART
design: Studio Mariani

OLV

CS

Base Material:
Solid Brass - Ottone

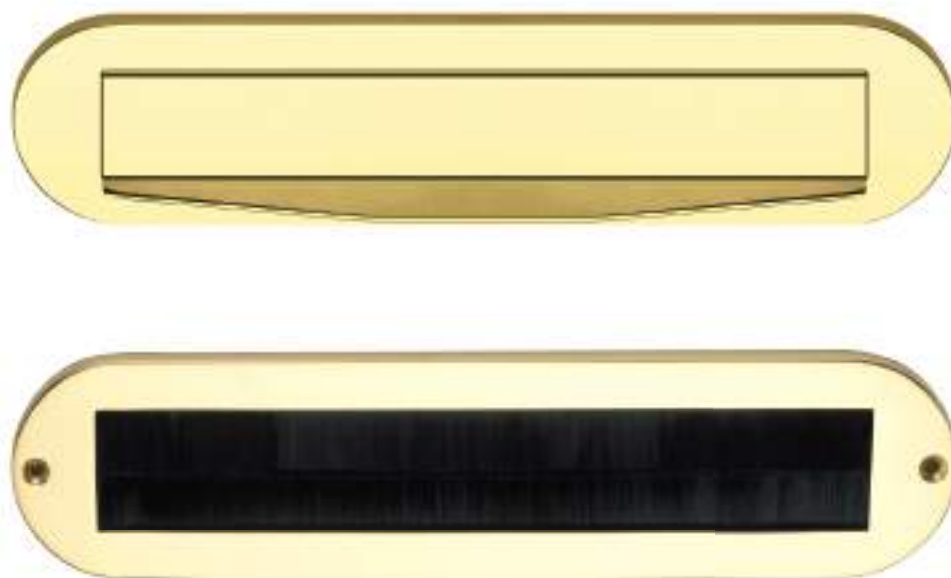

G3T-HA0

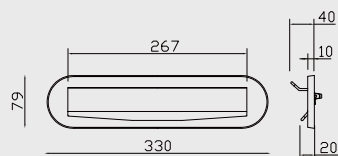

Hans bucalettere esterno
Hans external letter plate

 n. 1 pz

G3T-AR0

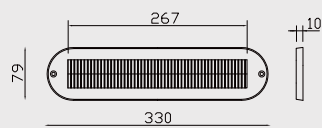

Art bucalettere interno
Art internal letter plate

 n. 1 pz

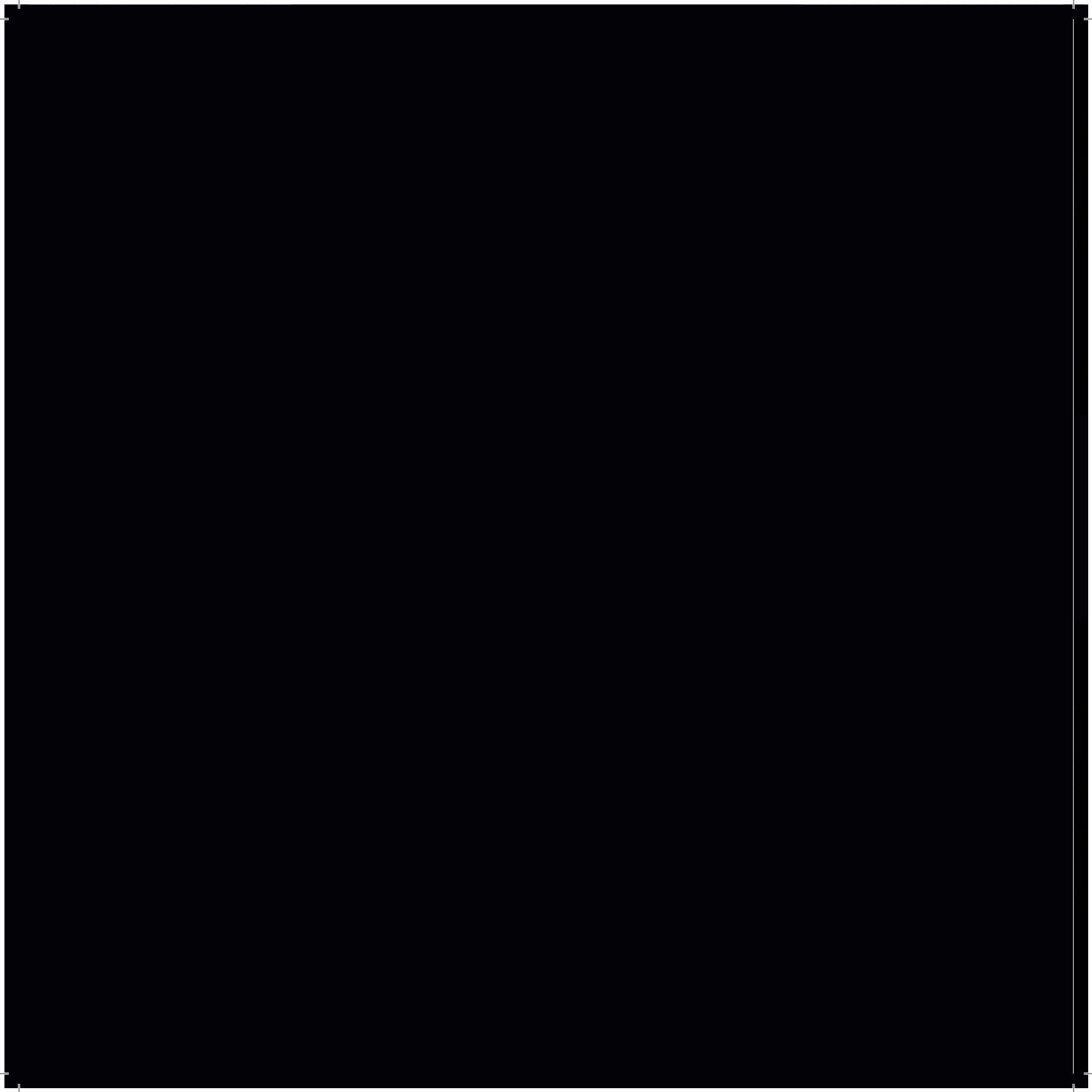

DESIGN MARIANIDESIGN MARIANIDESIGN
MARIANIDESIGN MARIANIDESIGN MARIANIDESIGN
MARIANIDESIGN MARIANIDESIGN MARIANIDESIGN
DESIGN MARIANIDESIGN MARIANIDESIGN MARIANIDESIGN

PLACCHE INCASSO

FLUSCH PLATES

DESIGN MARIANIDESIGN MARIANIDESIGN MARIANIDESIGN
MARIANIDESIGN MARIANIDESIGN MARIANIDESIGN
DESIGN MARIANIDESIGN MARIANIDESIGN MARIANIDESIGN
MARIANIDESIGN MARIANIDESIGN MARIANIDESIGN
MARIANIDESIGN MARIANIDESIGN

mariani

XBE UNO
design: Studio Mariani



OLV

CS

CR

YEB

Base Material:
Solid Brass - Ottone



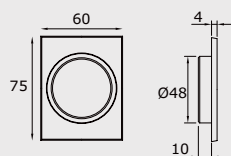

G1N-XB1

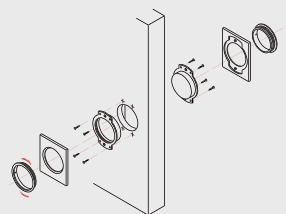

Xbe Uno placca incasso
Xbe Uno flush plate

SET "A"



Coppia placca incasso cieca
Set flush plate blind  n. 1 set

SET "B"

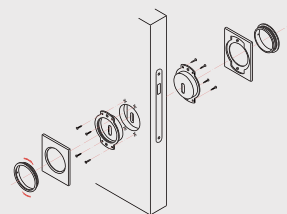

Coppia placca incasso con foro chiave
Set flush plate with standard key hole  n.1 set

SET "C"

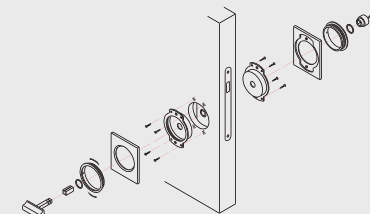

Coppia placca incasso con nottolino
Set flush plate with turn and release  n. 1 set

mariani

XBE DUE
design: Studio Mariani



OLV

CS

CR

YEB

Base Material:
Solid Brass - Ottone

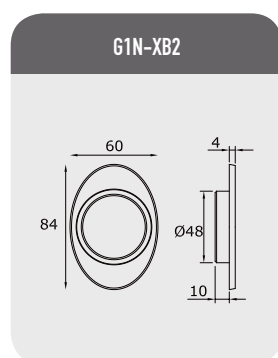

Xbe Due placca incasso
Xbe Due flush plate

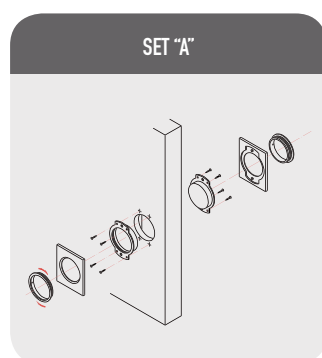

Coppia placca incasso cieca
Set flush plate blind  n. 1 set

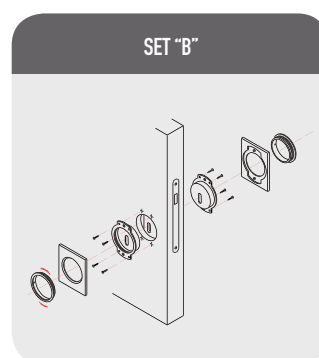

Coppia placca incasso con foro chiave
Set flush plate with standard key hole  n.1 set

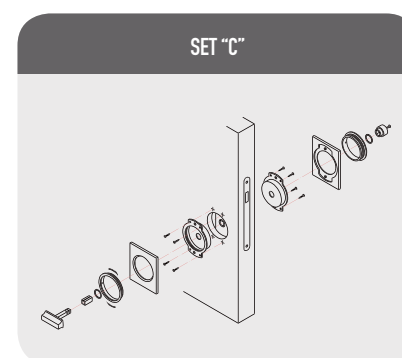

Coppia placca incasso con nottolino
Set flush plate with turn and release  n. 1 set



mariani

XBE TRE
design: Studio Mariani



OLV

CS

CR

YEB

Base Material:
Solid Brass - Ottone

G1N-XB3

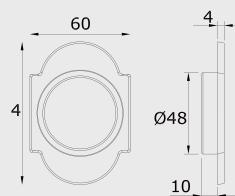

Xbe Tre placca incasso
Xbe Tre flush plate

SET "A"

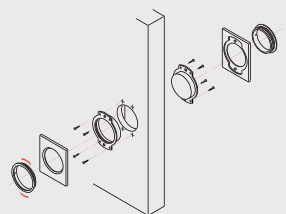

Coppia placca incasso cieca
Set flush plate blind  n. 1 set

SET "B"

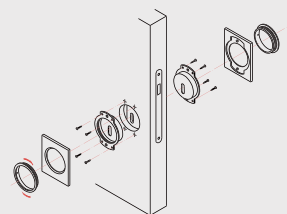

Coppia placca incasso con foro chiave
Set flush plate with standard key hole  n.1 set

SET "C"

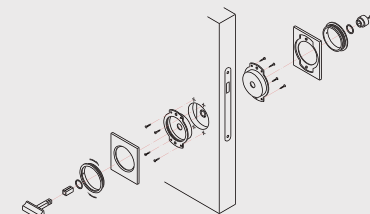

Coppia placca incasso con nottolino
Set flush plate with turn and release  n. 1 set

mariani

G1N-ONZ

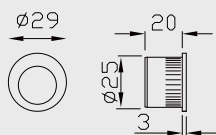

Onda trascinatore frontale
Onda pull ring

 n. 24 pz

**ONDA
TRASCINATORE**

OLV

CR

G8N-CKT

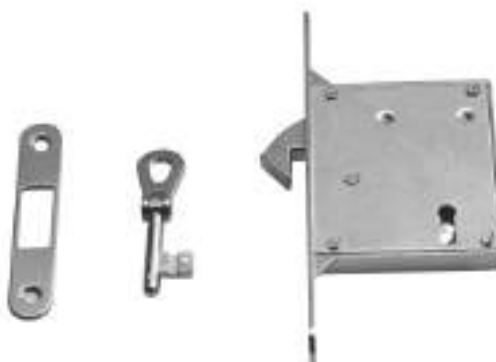
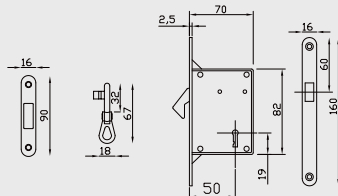

Serratura csv per porte scorrevoli: foro chiave - entrata 50mm
Locks for sliding door: key hole - backset 50mm  n. 5 pz

SERRATURA F.C.

OLV

CR

G8N-CQT

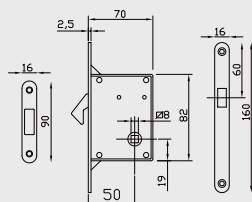

Serratura csv per porte scorrevoli: Quadro 8mm - entrata 50mm
Square 8mm: - backset 50mm  n. 5 pz

SERRATURA Q.8

OLV

CR

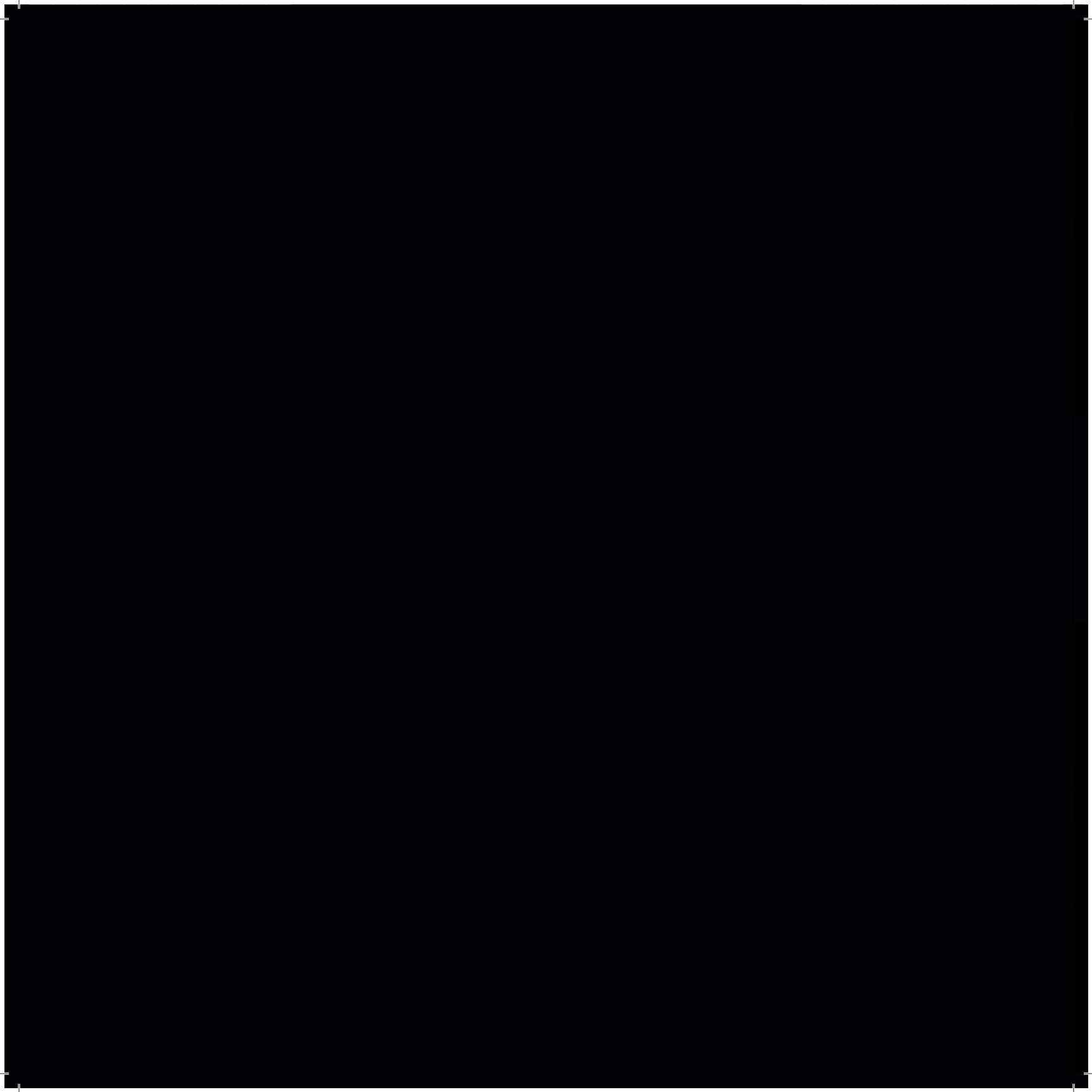

DESIGN MARIANDESIGN MARIANDESIGN
DESIGN MARIANDESIGN MARIANDESIGN MARIANDESIGN
DESIGN MARIANDESIGN MARIANDESIGN MARIANDESIGN
DESIGN MARIANDESIGN MARIANDESIGN MARIANDESIGN

BOCCHETTE WC
TURN AND RELEASES

DESIGN MARIANDESIGN MARIANDESIGN MARIANDESIGN
DESIGN MARIANDESIGN MARIANDESIGN MARIANDESIGN
DESIGN MARIANDESIGN MARIANDESIGN MARIANDESIGN
DESIGN MARIANDESIGN MARIANDESIGN MARIANDESIGN
DESIGN MARIANDESIGN MARIANDESIGN

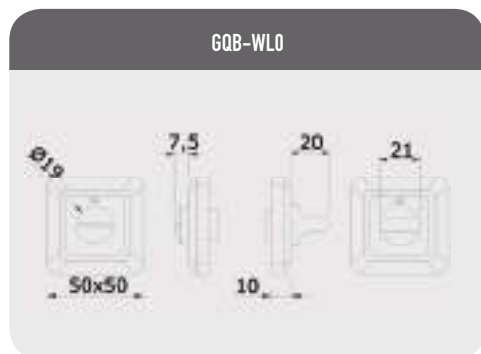

Qbe bocchetta WC Spagna
Qbe escutcheon with Spagna bathroom privacy set  n. 6 set

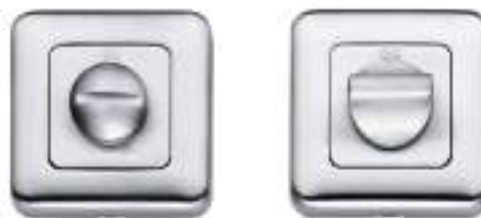

mariani

QBE WC



CS

CR

NS

YEB

Base Material:
Solid Brass - Ottone

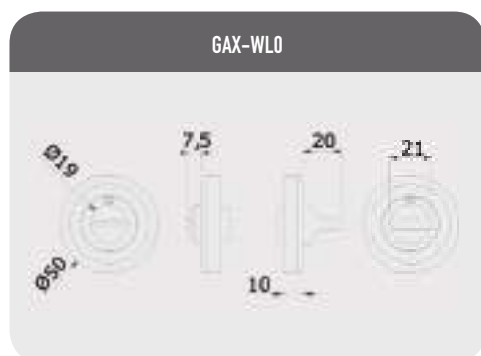

Artax bocchetta WC Spagna
Artax escutcheon with Spagna bathroom privacy set  n. 5 set



ARTAX WC



OLV

CS

CR

NS

YEB

Base Material:
Solid Brass - Ottone

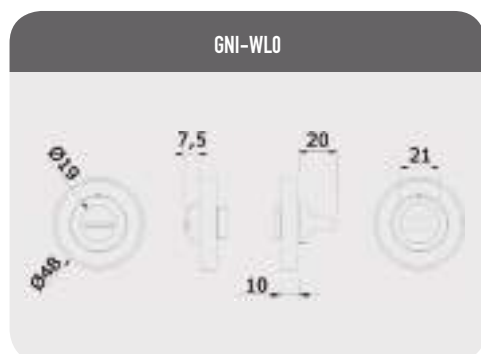

Nika bocchetta WC Spagna
Nika escutcheon with Spagna bathroom privacy set  n. 5 set

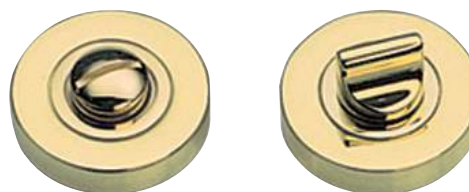

mariani

NIKA WC



OLV

CS

CR

NS

YEB

Base Material:
Solid Brass - Ottone

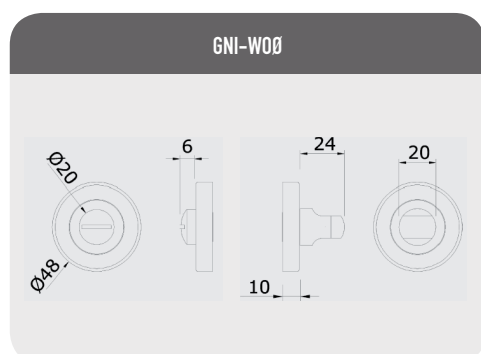

Nika bocchetta WC Oceania Quadro 4,6
Nika escutcheon with Oceania bathroom privacy set
squadre spindle 4,6  n. 5 set



NIKA OCEANIA WC

OLV

CS

CR

NS

YEB

Base Material:
Solid Brass - Ottone

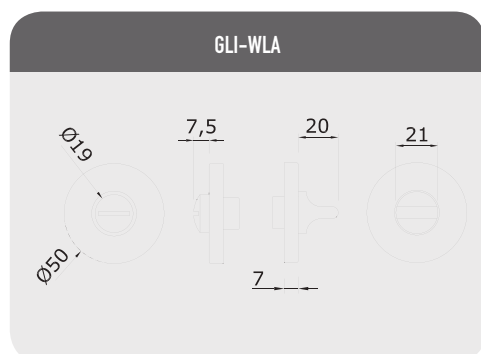

Linz bocchetta WC Spagna
Linz escutcheon with Spagna bathroom privacy set  n. 5 set



LINZ WC



CS

CR

NS

Base Material:
Solid Brass - Ottone

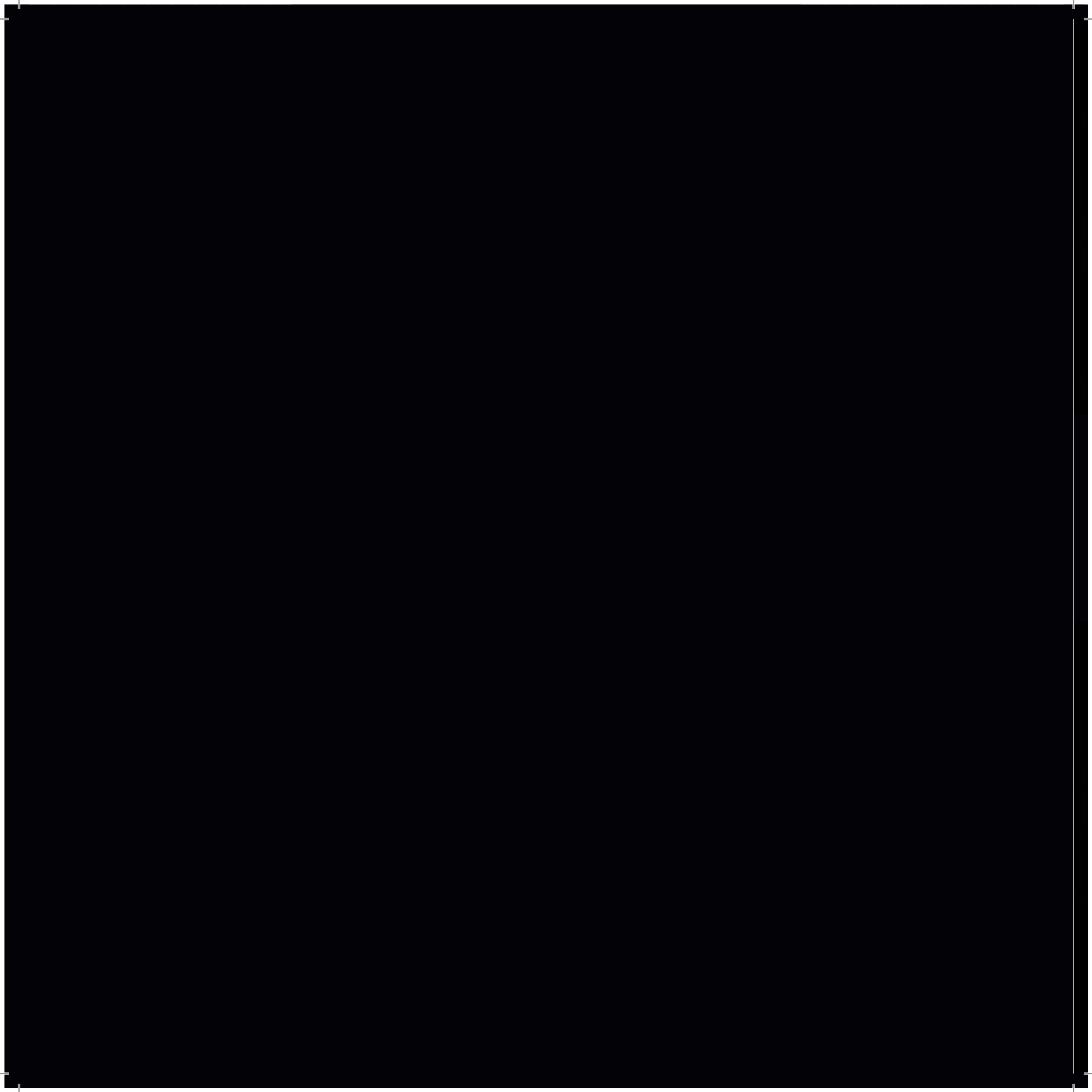

DESIGN MARIANDESIGN MARIANDESIGN
SIGN MARIANDESIGN MARIANDESIGN MARIANDESIGN
RIANDESIGN MARIANDESIGN MARIANDESIGN
SIGN MARIANDESIGN MARIANDESIGN MARIANDESIGN

BOCCHETTE

KEY HOLES

DESIGN MARIANDESIGN MARIANDESIGN MARIANDESIGN
RIANDESIGN MARIANDESIGN MARIANDESIGN
SIGN MARIANDESIGN MARIANDESIGN MARIANDESIGN
RIANDESIGN MARIANDESIGN MARIANDESIGN
RIANDESIGN MARIANDESIGN

G2B-QB2



Qbe Paia Bocchette FC/Yale
Qbe pair key hole PK/Yale

 n. 12 set



G2B-AX2



Artax paia Bocchette FC/Yale
Artax pair key hole PK/Yale

 n. 12 set



I2B-AX1



Artax paia Bocchette FC/Yale
Artax pair key hole PK/Yale

 n. 12 set



G2B-NI2



Nika Paia Bocchette FC/Yale
Nika pair key hole PK/Yale

 n. 10 set



mariani®

QBE

CS
CR
NS
YEB



Base Material:
Solid Brass - Ottone

ARTAX

OLV
CS
CR
NS
YEB



Base Material:
Solid Brass - Ottone

ARTAX INOX

INS
INSL



Base Material:
Staninless Steel
Acciaio INOX

NIKA

OLV
CS
CR
NS
YEB

Base Material:
Solid Brass - Ottone

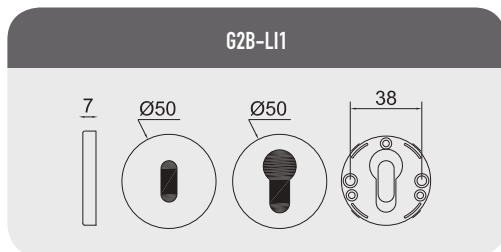

Linz Paia Bocchette FC/Yale
Linz pair key hole PK/Yale

 n. 10 set

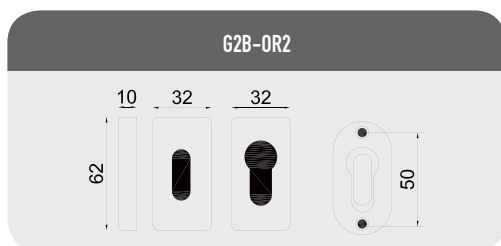

TP.Rt Paia Bocchette FC/Yale
TP.Rt pair key hole PK/Yale

 n. 10 set

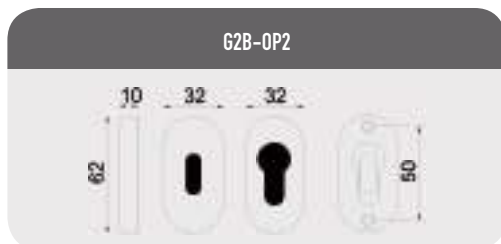

TP.Ov Paia Bocchette FC/Yale
TP.Ov pair key hole PK/Yale

 n. 10 set

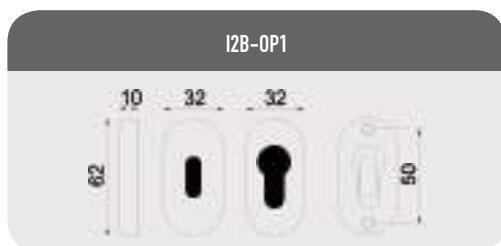

TP.Ov Paia Bocchette FC/Yale
TP.Ov pair key hole PK/Yale

 n. 10 set



mariani

LINZ

CS
CR
NS
YEB

Base Material:
 Solid Brass - Ottone

TP-RT.

CS
CR
NS
YEB

Base Material:
 Solid Brass - Ottone

TP-OV.

OLV
CS
CR
NS
YEB

Base Material:
 Solid Brass - Ottone

TP-OV. INOX

INS
INSL

Base Material:
 Stainless Steel
Acciaio INOX

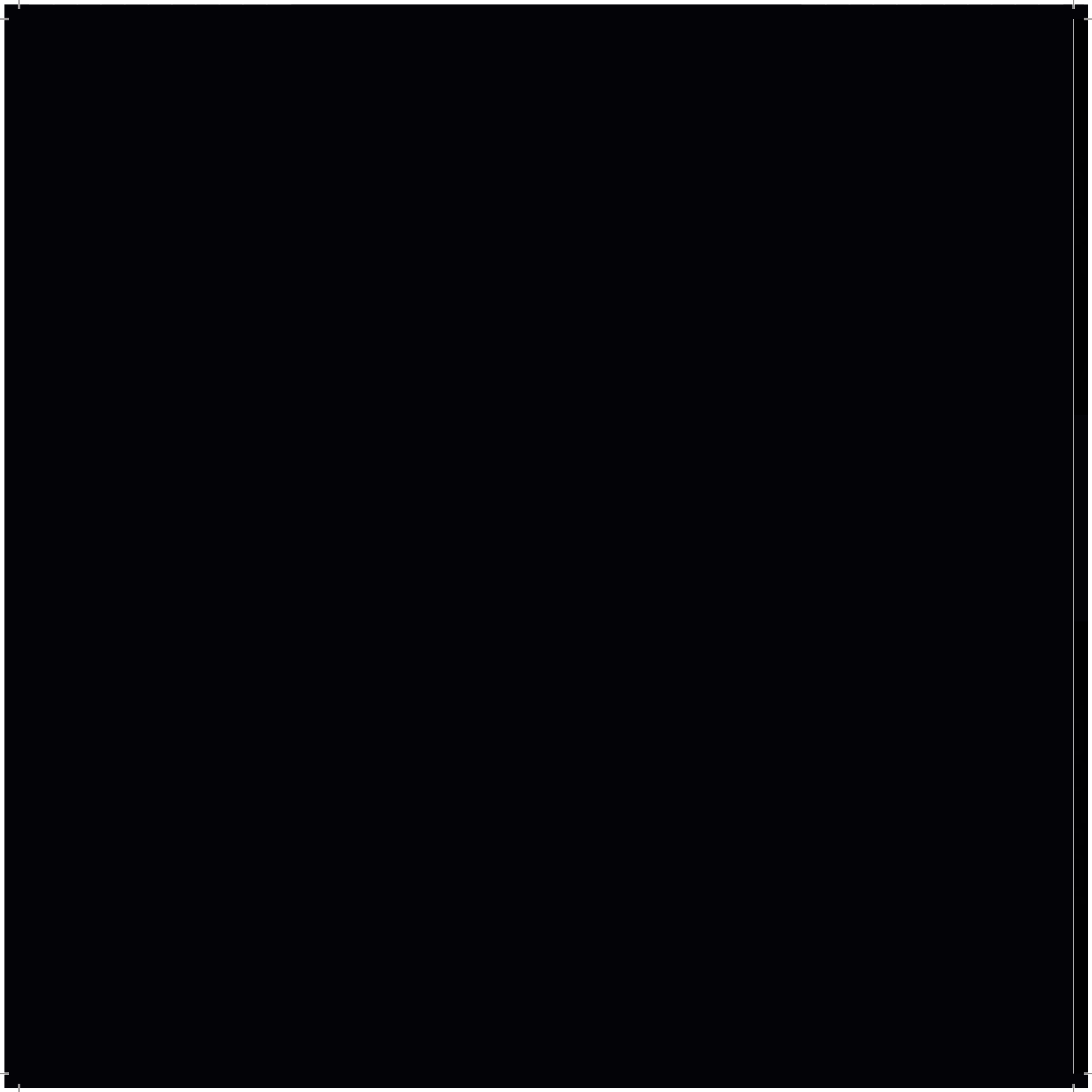

ROSETTE
ROSES

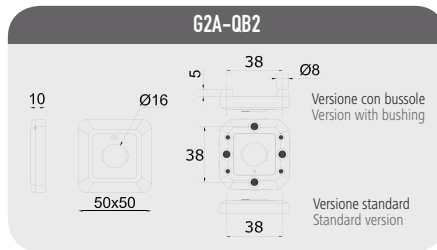

Qbe paia rosette
Qbe pair roses

n. 10 set

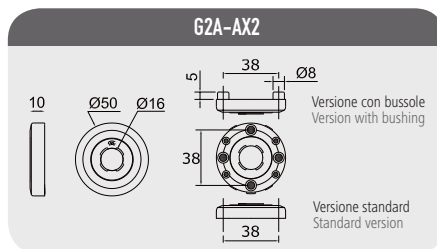

Artax paia rosette
Artax pair roses

n. 10 set

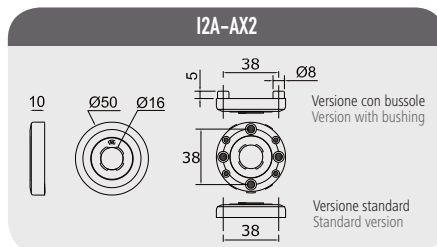

Artax Inox paia rosette
Artax Stainless pair roses

n. 10 set

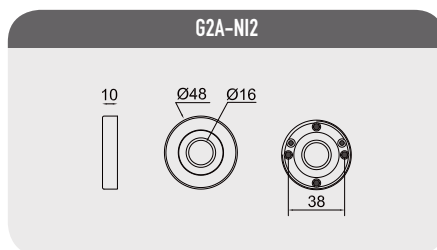

Nika paia rosette
Nika pair roses

n. 10 set

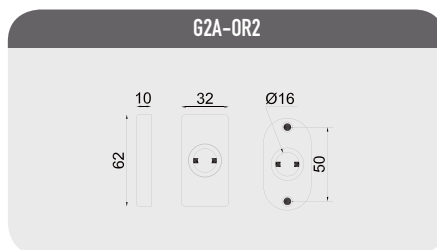

TP.Rt paia rosette
TP.Rt pair roses

n. 10 set

mariani®

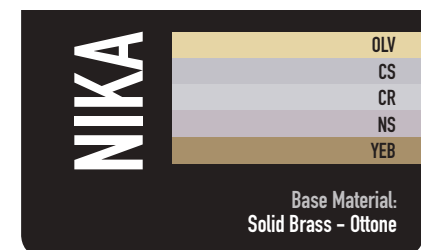

G2A-OP2



TP.Ov paia rosette
TP.Ov pair roses

n. 10 set

I2A-OP2

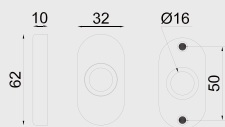

TP.Ov paia rosette
TP.Ov pair roses

n. 10 set

G2E-QBI

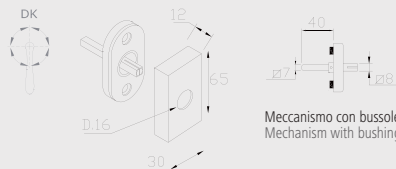

Meccanismo con bussole
Mechanism with bushing

Qbe Rosetta Dreh-Kipp + meccanismo Std
Qbe rose Dreh-Kipp + Std. mechanism

n. 25 pz

G2E-NII

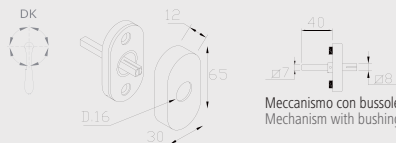

Meccanismo con bussole
Mechanism with bushing

Nika Rosetta Dreh-Kipp + meccanismo Std
Nika rose Dreh-Kipp + Std. mechanism

n. 25 pz

I2E-OVI



Meccanismo con bussole
Mechanism with bushing

Ovale Inox Rosetta Dreh-Kipp + meccanismo Std
Ovale Inox rose Dreh-Kipp + Std. mechanism

n. 25 pz

mariani®

TP-OV.

OLV
CS
CR
NS
YEB



Base Material:
Solid Brass - Ottone

TP-OV. INOX

INS
INSL



Base Material:
Stainless Steel
Acciaio INOX

QBE DK

CS
CR
NS
YEB



Base Material:
Solid Brass - Ottone

NIKA DK

OLV
CS
CR
NS
YEB



Base Material:
Solid Brass - Ottone

OVALE DK INOX

INS
INSL



Base Material:
Stainless Steel
Acciaio INOX

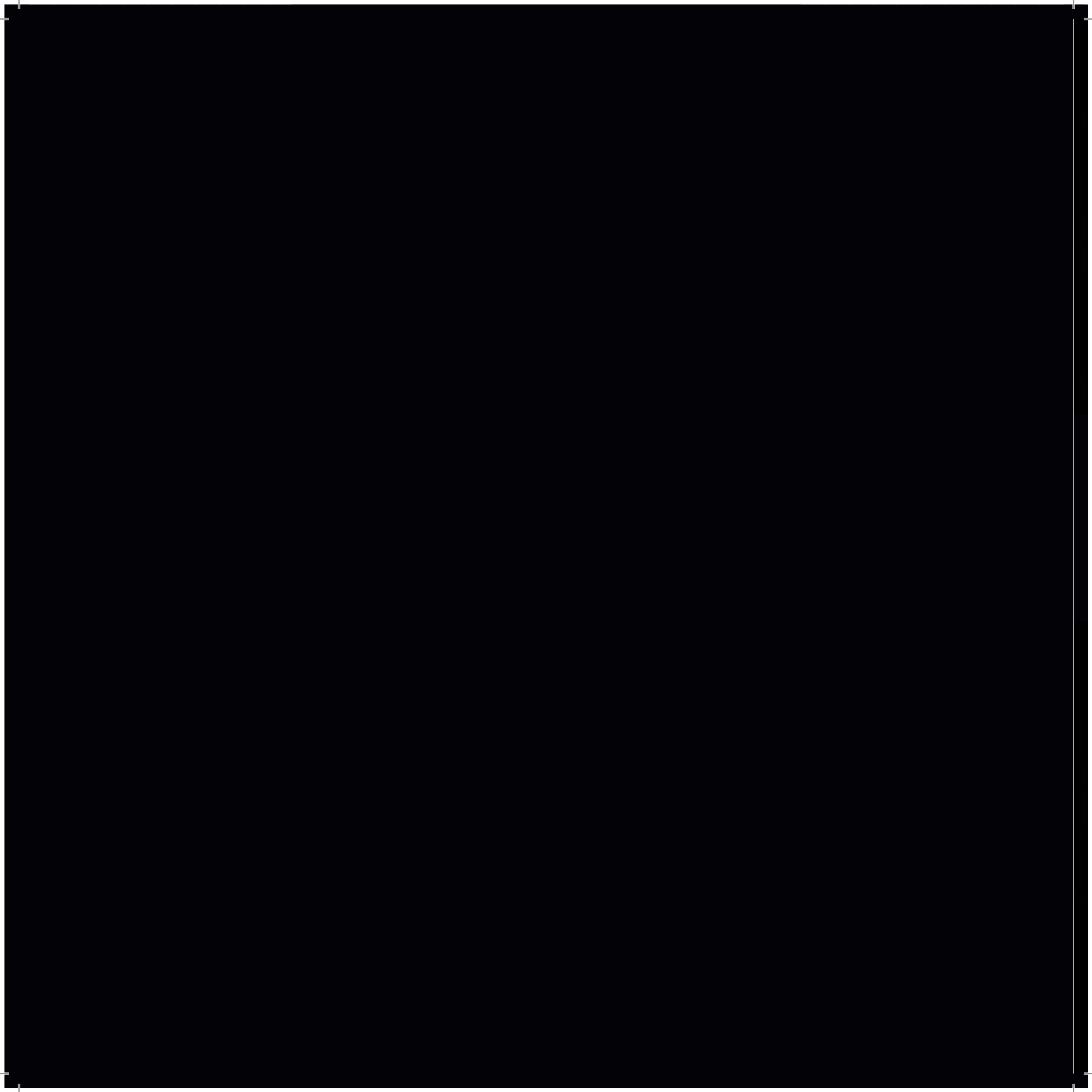

DESIGN MARIANIDESIGN MARIANIDESIGN
MARIANIDESIGN MARIANIDESIGN MARIANIDESIGN
MARIANIDESIGN MARIANIDESIGN MARIANIDESIGN
DESIGN MARIANIDESIGN MARIANIDESIGN MARIANIDESIGN

PLACCHE
PLATES

DESIGN MARIANIDESIGN MARIANIDESIGN MARIANIDESIGN
MARIANIDESIGN MARIANIDESIGN MARIANIDESIGN
DESIGN MARIANIDESIGN MARIANIDESIGN MARIANIDESIGN
MARIANIDESIGN MARIANIDESIGN MARIANIDESIGN
DESIGN MARIANIDESIGN MARIANIDESIGN

GL1-CAO

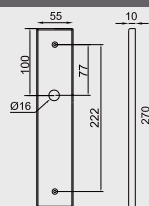

Libra paia placche
Libra pair plates

 n. 5 set

GAA-CAO

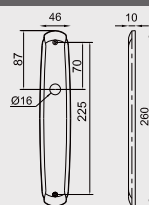

Asia paia placche
Asia pair plates

 n. 6 set

GAS-CAO

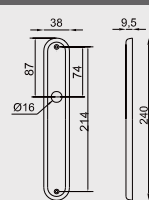

Astra paia placche
Astra pair plates

 n. 6 set

GTH-CAO

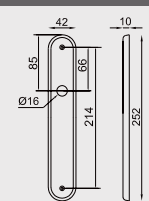

Thalassia paia placche
Thalassia pair plates

 n. 6 set

GZE-CAO

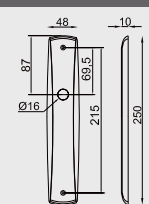

Zoe paia placche
Zoe pair plates

 n. 6 set

mariani®

LIBRA

CS
CR
NS
YEB



Base Material:
Solid Brass - Ottone

ASIA

OLV
CS
YEB

Base Material:
Solid Brass - Ottone

ASTRA

OLV
CS
CR
NS
YEB

Base Material:
Solid Brass - Ottone

THALASSIA

OLV
CS
CR
NS
YEB

Base Material:
Solid Brass - Ottone

ZOE

OLV
CS
YEB

Base Material:
Solid Brass - Ottone

mariani®

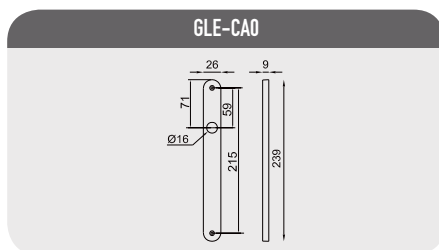

Linea paia placche
Linea pair plates

n. 10 set

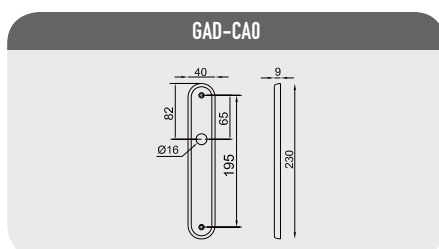

Aladin paia placche
Aladin pair plates

n. 6 set

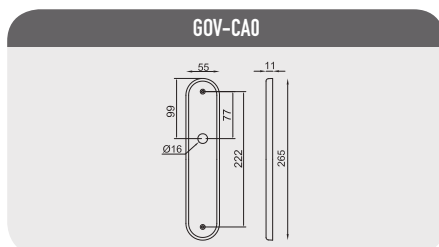

Oval paia placche
Oval pair plates

n. 6 set

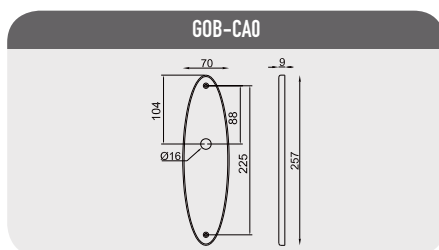

Ellisse paia placche
Ellisse pair plates

n. 6 set

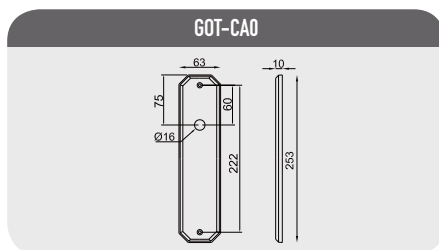

Ottagono paia placche
Ottagono pair plates

n. 6 set

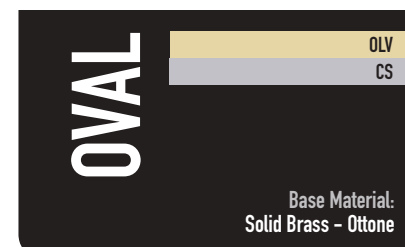
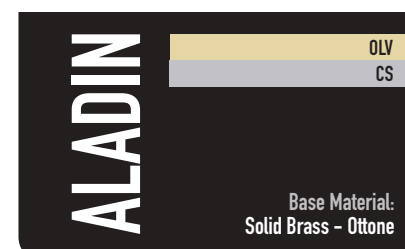

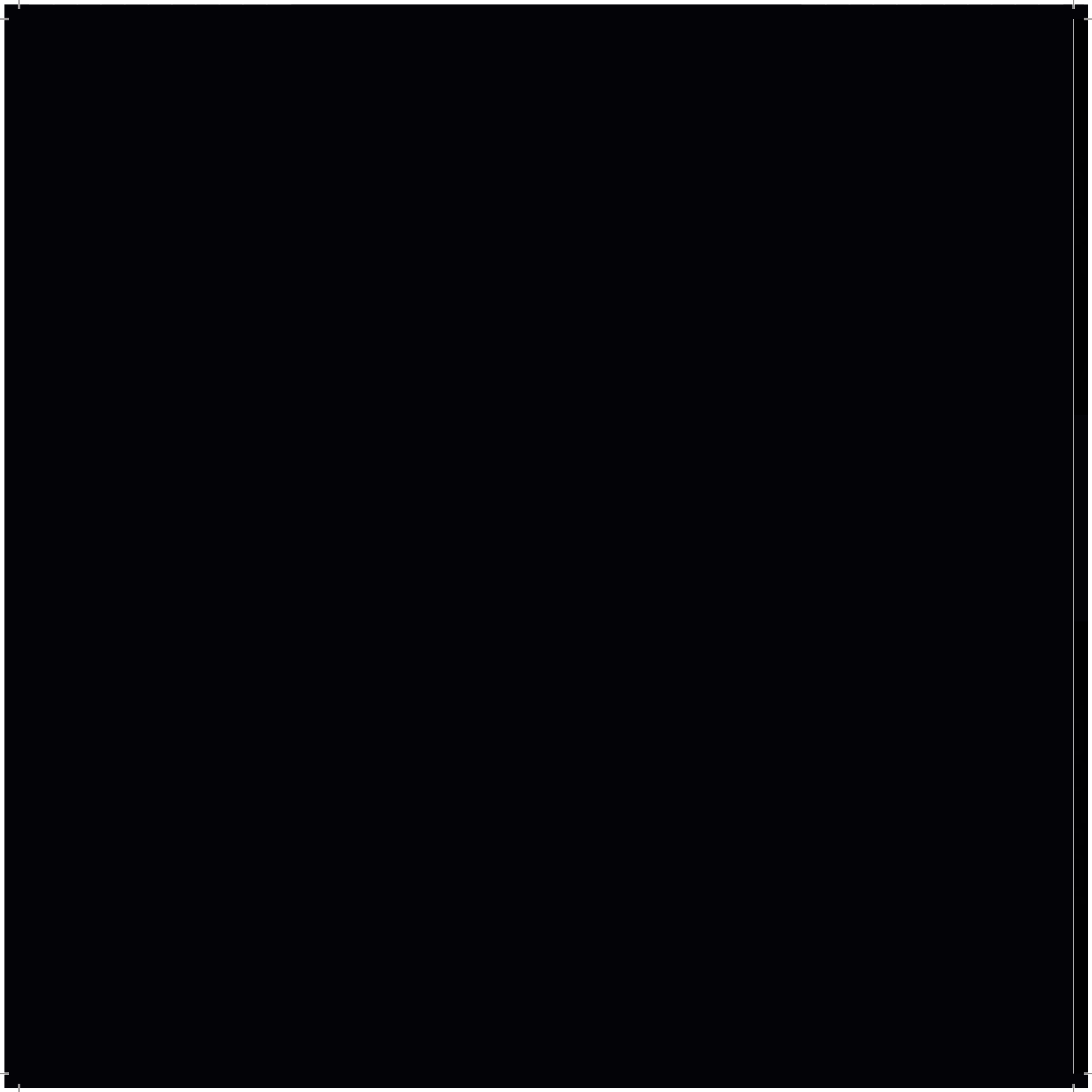

DESIGN MARIANDESIGN MARIANDESIGN
MARIANDESIGN MARIANDESIGN MARIANDESIGN
MARIANDESIGN MARIANDESIGN MARIANDESIGN
DESIGN MARIANDESIGN MARIANDESIGN MARIANDESIGN

ARTICOLI VARI

VARIOUS ARTICLES

DESIGN MARIANDESIGN MARIANDESIGN MARIANDESIGN
MARIANDESIGN MARIANDESIGN MARIANDESIGN MARIANDESIGN
DESIGN MARIANDESIGN MARIANDESIGN MARIANDESIGN
MARIANDESIGN MARIANDESIGN MARIANDESIGN MARIANDESIGN

mariani®

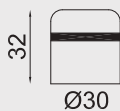
G7K-R00

Ferma porta con tassello di fissaggio (D.30xH32)
Door stopper (D.30xH32)

 n. 20 pz

OLV
CS

Base Material:
Solid Brass - Ottone

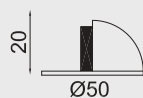
G7K-B00

Ferma porta (D.50xH20)
Door stopper (D.50xH20)

 n. 10 pz

OLV
CS

Base Material:
Solid Brass - Ottone

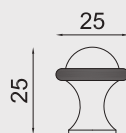
G7K-P00

Ferma porta con tassello di fissaggio (D.25xH25)
Door stopper (D.25xH25)

 n. 20 pz

OLV
CS

Base Material:
Solid Brass - Ottone

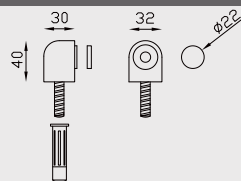
G7K-321

GRA-321 Ferma porta magnetico con tassello di fissaggio
GRA-321 Magnetic door stopper

 n. 5 pz

OLV
CS

Base Material:
Solid Brass - Ottone

mariani®

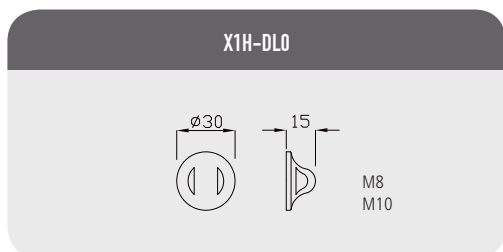

Dado
Nut

 n. 10 spz

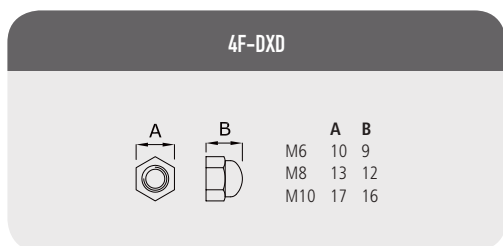

Dado
Nut

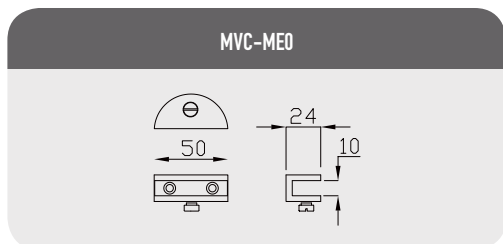

Supporto per mensola cristallo
Shelf brackets for crystal

 n. 12 pz

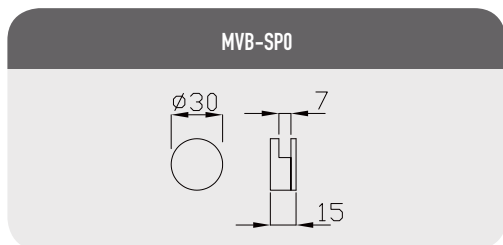

Supporto per mensola cristallo
Shelf brackets for crystal

 n. 12 pz

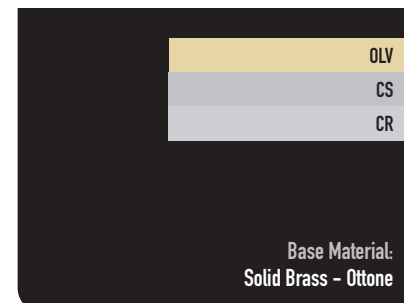
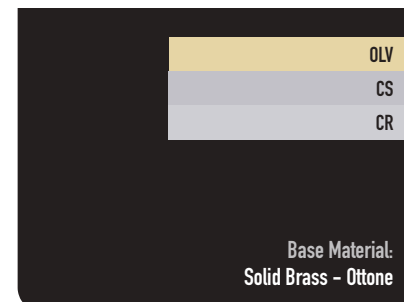
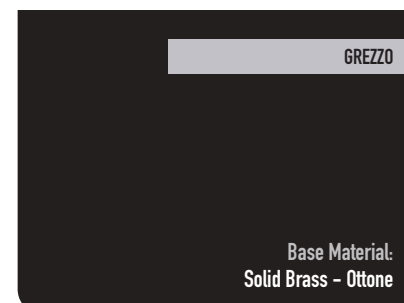
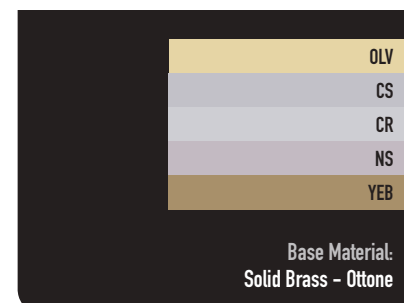

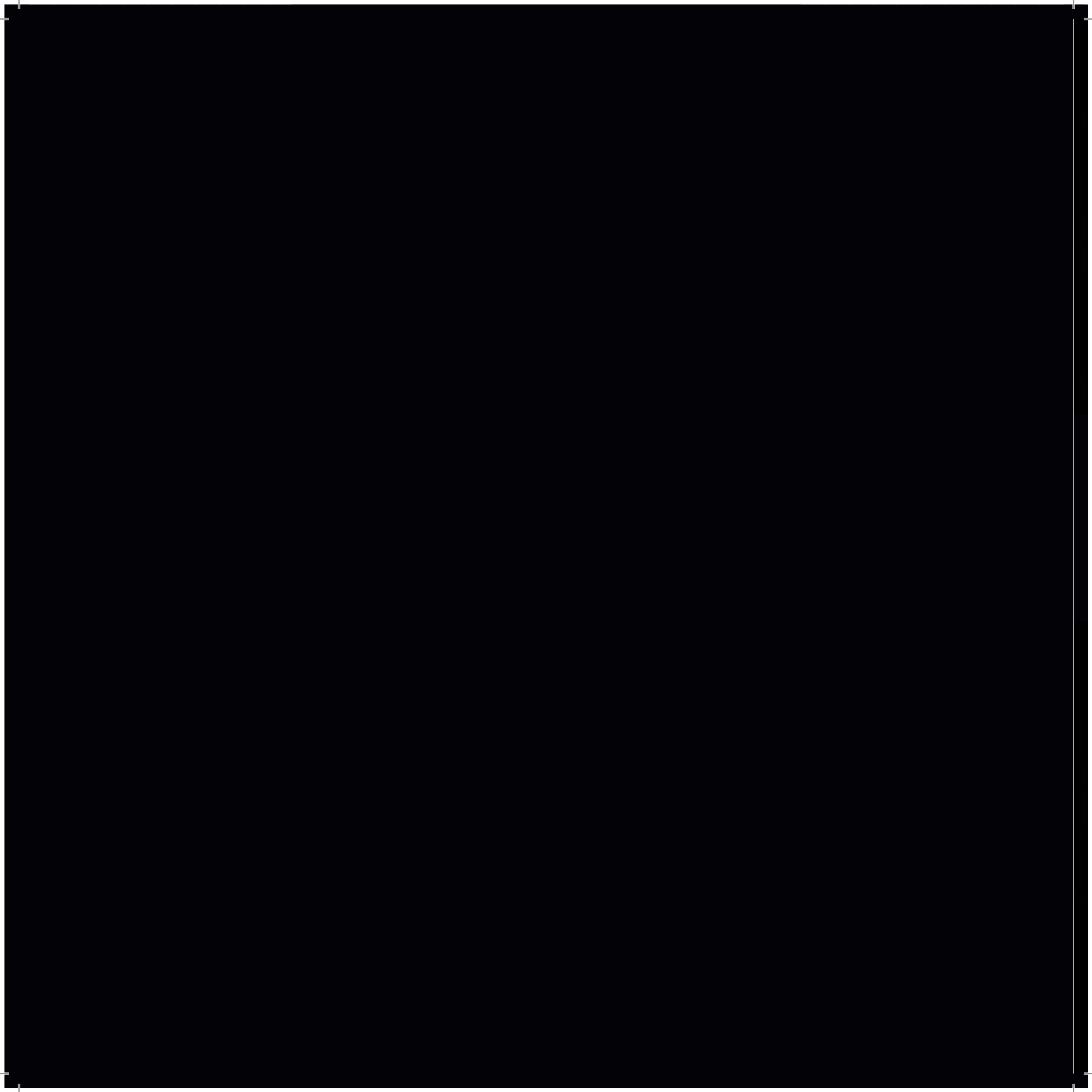

DESIGN MARIANDESIGN MARIANDESIGN
MARIANDESIGN MARIANDESIGN MARIANDESIGN
MARIANDESIGN MARIANDESIGN MARIANDESIGN
DESIGN MARIANDESIGN MARIANDESIGN MARIANDESIGN

ACCESSORI

ACCESSORIES

DESIGN MARIANDESIGN MARIANDESIGN MARIANDESIGN
MARIANDESIGN MARIANDESIGN MARIANDESIGN MARIANDESIGN
DESIGN MARIANDESIGN MARIANDESIGN MARIANDESIGN
MARIANDESIGN MARIANDESIGN MARIANDESIGN MARIANDESIGN



KIT VITI - SCREW KIT

4F-DSDUA

Set 4 viti per placca
 Finiture BR NI OT
 Set of 4 screws for plate
 Finishing BR NI OT

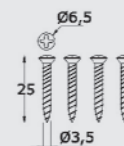
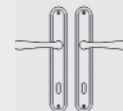
**4F-DSDUG**

Set 2 grani + chiave + 14 viti per
 rosetta/bocchetta
 Finiture ZI
 Set 2 grubs screw + allen key
 + 14 screw for roses and key hole
 Finishing ZI

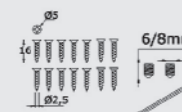
**4F-DSDUF**

Set 2 grani + chiave + 10 viti per
 rosetta/bocchetta
 Finiture ZI
 Set 2 grubs screw + allen key
 + 10 screw for roses and key hole
 Finishing ZI

**4F-DUDUF**

Set 2 grani + chiave + 6 viti per
 rosetta
 Finiture ZI
 Set 2 grubs screw + allen key
 + 6 screw for roses
 Finishing ZI

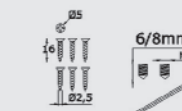
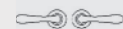
**4F-DSDUC4**

Set 4 viti per bocchetta
 Finiture ZI
 Set 4 screw + for key hole
 Finishing ZI

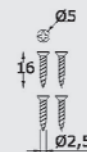
**4F-DSDUC8**

Set 2 grani + chiave + 8 viti per
 rosetta/bocchetta - OP Ovale
 Finiture ZI
 Set 2 grubs screw + allen key + 8
 screw for oval roses and key hole.
 Finishing ZI

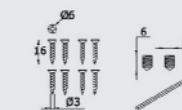
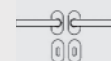

KIT VITI - SCREW KIT

4F-DSDUN

Set 2 viti Assa passanti con bussole
 Finiture BR NI OT
 Set 2 bolt through screw with bushing
 Finishing BR NI OT

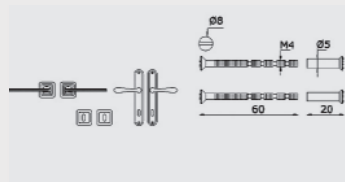
**69-KC240**

Set viti passanti con bussole
 per sottorosette/bocchette in ottone
 Finiture ZI
 Set 2 bolt through screw with
 bushing for brass under roses/ key
 hole
 Finishing ZI

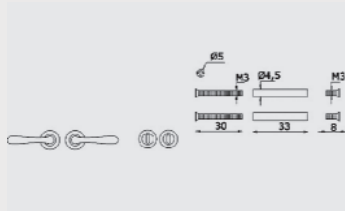
**4F-DUDUS**

Set 2 viti grano + chiavetta
 Finiture ZI
 Set 2 grubs screw allen key
 Finishing ZI

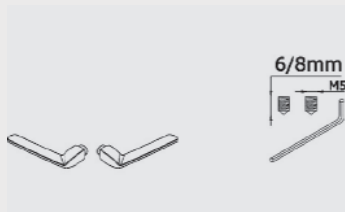
**4F-DUDUS**

Set 1 viti grano + chiavetta
 Finiture ZI
 Set 1 grubs screw allen key
 Finishing ZI

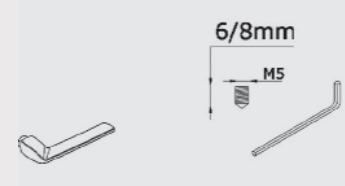
**4F-DUDUS**

Set 2 viti grano inox + chiavetta
 Finiture INOX
 Set 2 stainless steel grubs screw
 allen key
 Finishing INOX

**4F-DINOX**

Set 2 viti grano inox + chiavetta
 Finiture INOX
 Set 2 stainless steel grubs screw
 allen key
 Finishing INOX

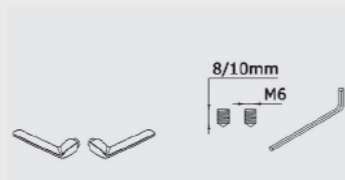
**4F-DSDUC2**

Set 2 viti per bucalettere
 Finiture ZI
 Set 2 screw for letter plates
 Finishing ZI

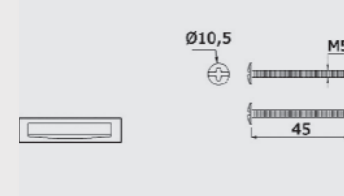
**4F-DW565**

Set 2 viti per bucalettere esterno
 + interno
 Finiture BR NI OT
 Set 2 screw for inside + outside
 letter plate
 Finishing BR NI OT

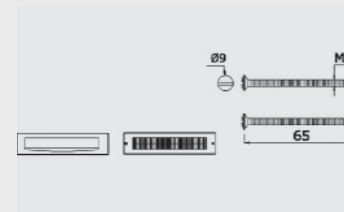
**FINITURE**

BR Bonzate - Bronzed
INOX Acciaio inox - Stainless steel
NI Nichelate - Nickled
OT Ottonate - Brassed
ZI Zincate - Zinc



FERRI QUADRI - SQUARE SPINDLES

4F-AAA8

Ferro quadro Normale
Normal square spindle

Cod	Lung. - Length
4F-AAA8	65
4F-AAA8	85
4F-AAA8	95
4F-AAA8	105

**4F-ACA08**

Ferro quadro con 2 tagli fresati
Square spindle with two milled slots

Cod	Lung. - Length
4F-ACA08	85
4F-ACA08	100
4F-ACA08	105
4F-ACA08	155

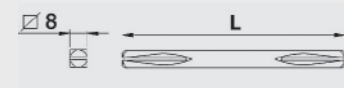
**4F-AKA8**

Ferro quadro con bloccaggio ad espansione
Square spindle with expanding block

Cod	Lung. - Length
4F-AKA8	65
4F-AKA8	80

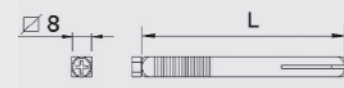
**4F-AHA8**

Ferro quadro con bloccaggio
Square spindle with block

Cod	Lung. - Length
4F-AHA8	67
4F-AHA8	90

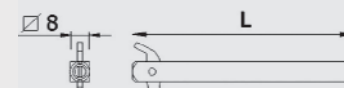
**4F-AUA8**

Ferro quadro snodato
Joint square spindle

Cod	Lung. - Length
4F-AUA8	80
4F-AUA8	90
4F-AUA8	100

**4F-AYA8**

Ferro Dummy per pomolo fisso
Dummy spindle for fixed knobs



FERRI QUADRI - SQUARE SPINDLES

4F-ANA8

Ferro quadro con rondella in testa
con taglio fresato
Square spindle with washer and slot

Cod Lung. - Length
4F-ANA8 50
4F-ANA8 60

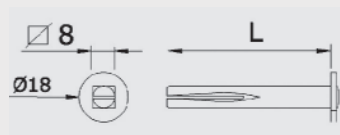
**4F-AAA7**

Ferro quadro normale
Normal square spindle

Cod Lung. - Length
4F-AAA7 70

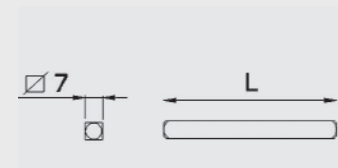
**4F-ALA8**

Ferro quadro con nipples girevole
con taglio fresato
Square spindle with moveable
nipples and slot

Cod Lung. - Length
4F-ALA8 65
4F-ALA8 75
4F-ALA8 95

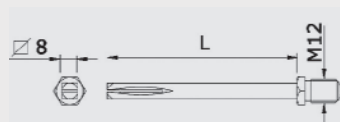
**4F-AAA6**

Ferro quadro normale
Normal square spindle

Cod Lung. - Length
4F-AAA6 75

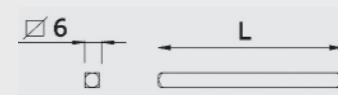
**4F-ACAE**

Ferro quadro con 2 tagli fresati
Square spindle with 2 milled slots

Cod Lung. - Length
4F-ACAE 85
4F-ACAE 95
4F-ACAE 105

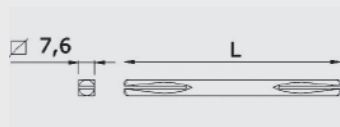
**4F-AWAD**

Ferro quadro normale
Normal square spindle

Cod Lung. - Length
4F-AWAD 80

**4F-AAA7**

Ferro quadro con 2 fresate
Square spindle with 2 milled slots

Cod Lung. - Length
4F-AAA7 85
4F-AAA7 95
4F-AAA7 105

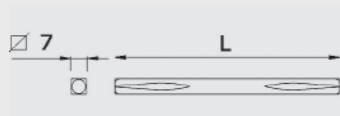
**4F-AWAE**

Ferro quadro normale
Normal square spindle

Cod Lung. - Length
4F-AWAE 75

**4F-AEA6**

Ferro quadro con 2 fresate
Square spindle with 2 milled slots

Cod Lung. - Length
4F-AEA6 95
4F-AEA6 105

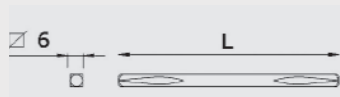
**4F-AY5B**

Ferro Dummy per battenti
Dummy spindle for door knockers

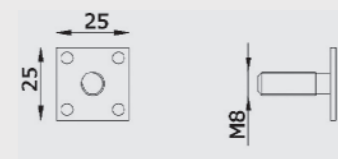



MOLLE - SPRINGS

4F-DADA

Molla a chiocciola
Winding spring

**4F-DPDH**

Piastrina fermamolla
Spring + spring stop

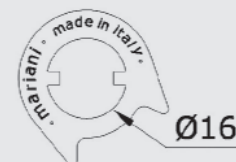
**X4-AFSP**

Molla fissa ambidestra per
placche
Ambidextrous fixed spring
for plates

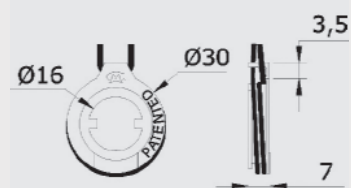
**X4-AAPP**

Molla sistema ad applicare
ambidestra per placche
Ambidextrous spring to be
applied for plates

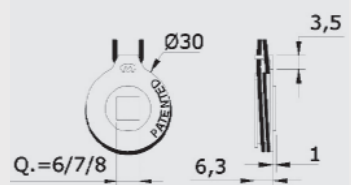
**X4-AFSR**

Molla fissa ambidestra per
rosette con 5 fori vite
Kira/Nika/Astra/Paloma/Windsor
Ambidextrous fixed spring
for roses with 5 screw holes
Kira/Nika/Astra/Paloma/Windsor

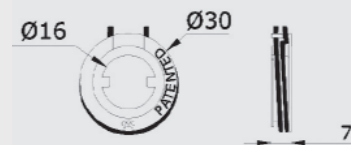
**X4-AAPR**

Molla sistema ad applicare
ambidestra per rosette con 5 fori vite
Kira/Nika/Astra/ Paloma/Windsor.
Ambidextrous spring to be applied for
roses with 5 screw holes
Kira/Nika/Astra/Paloma/Windsor.

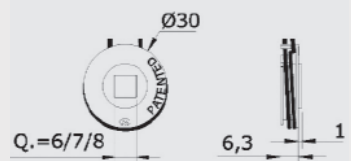

RIDUZIONI QUADRE - SQUARE REDUCTIONS

4F-EXEC

Riduzioni in ferro
Square metal reduction

Ext.	int.	L.
7	6	30
8	6	20
8	6	30
8	7	20
8	7	30
8,5	8	30
9	8	30
10	8	30

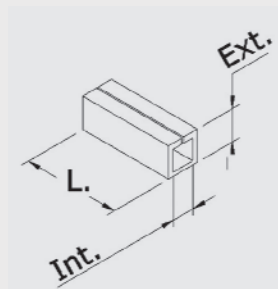
**3P-EXEC**

Riduzioni in plastica
Square plastic reduction

Ext.	int.	L.
7	6	22
8	5	30
8	6	30
8	7	28

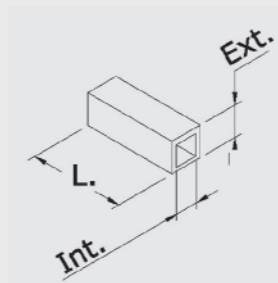

CONVENZIONI MANO - HANDING

1

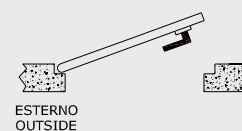
**LH**

SINISTRA - LEFT HAND

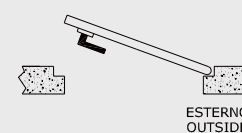

2

**RH**

DESTRA - RIGHT HAND

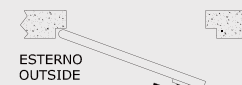

3

**LH-R**

SINISTRA INVERSA - LEFT HAND REVERSE



4

**RH-R**

DESTRA INVERSA - RIGHT HAND REVERSE



FINITURE FINISHING



OLV

Ottone lucido verniciato

Polished laquered brass



OS

Ottone satinato

Satinated brass



CR

Ottone cromato lucido

Bright chrome polished brass



CS

Ottone cromato satinato

Satin chrome polished brass



CSCR/CRCS

Ottone cromato lucido + satinato

Bright chrome polished brass + Satin chrome polished brass



NS

Ottone nichelato satinato

Satin nickel brass



NLV

Ottone nichelato lucido

Bright nickel polished brass



NSNL/NLNS

Ottone nichelato lucido + satinato

Bright nickel polished brass + Satin nickel brass



INS

Acciaio inox satinato

Satin stainless steel



YEB

Ottone bronzato graffiato opaco

Matt yester bronze brass



OGR

Ottone bronzato graffiato lucido

Polished yester bronze brass

**AB****Ottone bronzato antico**

Antique laquered brass

**SIB****Ottone ferro antico**

Steel iron brass

**MBB****Ottone bronzato opaco light**

Light oil rubbed brass

**DOR****Ottone bronzato opaco dark**

Dark oil rubbed brass

**PVD****Ottone con rivestimento metallico sottovuoto antigraffio/antiossidante**

Physical Vapour Deposition

**PVD NK****Ottone con rivestimento metallico sottovuoto antigraffio/antiossidante**

Physical Vapour Deposition

**PVD INOX****Ottone con rivestimento metallico sottovuoto antigraffio/antiossidante**

Physical Vapour Deposition

**PVD-GRA****Ottone con rivestimento metallico sottovuoto antigraffio/antiossidante**

Physical Vapour Deposition

**PLO****Ottone placcato oro 24K**

24K Gold plated brass

ESPOSITORI

**8A-MRMR45**

Espositore da banco 30x30xH.50

**8A-MRMR40**

Espositore da terra 30x30xH.150

PACKAGING



CONDIZIONI GENERALI DI VENDITA

ORDINI: Sia diretti che indiretti si intendono sempre salvo approvazione della venditrice e non possono essere revocati dal cliente. La loro evasione può essere anche parziale, con riserva della venditrice di annullare l'ordine per quanto riguarda la merce non disponibile. Per ordini provenienti dall'estero inferiori ad Euro 500,00 verrà addebitato l'importo di Euro 45,00 per contributo spese gestione ordine.

CONSEGNA: La merce viaggia sempre e in ogni caso ad esclusivo rischio e pericolo dell'acquirente che ha l'obbligo di ritirarla. In caso di mancato ritiro tutti i danni e le perdite conseguenti saranno a suo carico. I termini di consegna devono ritenersi sempre approssimativi. Eventuali vizi, mancanze di qualità, ammanchi o qualsiasi altra contestazione sulla merce consegnata, dovranno essere denunciati all'acquirente, sotto pena di decadenza, entro otto giorni dal ricevimento della merce stessa. Nella eventualità di mancata consegna per casi di forza maggiore e fortuiti, o per impedimenti di qualsiasi natura, il compratore non avrà diritto ad indennizzi, compensi o rimborsi.

TRASPORTO: Le spese di trasporto, salvo particolari convenzioni, sono a carico del compratore.

PAGAMENTO: La fattura relativa alla merce fornita deve essere pagata nei termini e nel luogo convenuti. Il ritardato pagamento della stessa darà luogo alla decorrenza degli interessi di mora nella misura di tre punti oltre il tasso ufficiale di sconto.

FORO COMPETENTE: Per qualsiasi azione giudiziaria, nonché per l'esame e la soluzione di qualsiasi vertenza e controversia, l'acquirente riconosce, a tutti gli effetti di legge, l'esclusiva competenza della autorità giudiziarie di Brescia.

La nostra società si riserva, in qualsiasi momento e senza preavviso, di adeguare i prodotti indicati nel presente catalogo. Per tutti gli articoli eliminati non risultanti a catalogo se disponibili, il prezzo verrà precisato di volta in volta.

SALES CONDITIONS

ORDERS: Orders received become binding only after our approval. Partial deliveries can be made with the reserve to cancel orders for goods not available.

For orders less than Euro 500,00 (except Italy) will be charges the amount of Euro 45,00 as management order costs.

DELIVERY: The goods travel at the customer's own risk even if free port. Delivery times are always to be considered approximate. Objections regarding items ordered will only be accepted if received within and not later than 8 days from the date of delivery. After this term, all invoices will be considered definitely approved and as such carried out. Damage claims for late deliveries will not be accepted.

TRANSPORT: Transport charges, except for special agreements, fall on buyer behalf.

PAYMENT: invoice concerning the goods sent must be paid within the agreed time. The late payment of invoices will result in the effect of interest on arrears to three points above the official discount rate.

COMPETENT LAW COURT.

For any dispute, the competence belongs to the Law-Court of Brescia (Italy) only.

Our Company reserves the right at any time to adapt and change items in this catalogue. The price of the items deleted from this catalogue will be announced from time to time.

DESIGN MARIANI DESIGN MARIANI DESIGN MARIANI DESIGN MARIANI
DESIGN MARIANI DESIGN MARIANI DESIGN MARIANI DESIGN MARIANI
DESIGN MARIANI DESIGN MARIANI DESIGN MARIANI DESIGN MARIANI
DESIGN MARIANI DESIGN MARIANI DESIGN MARIANI DESIGN MARIANI

mariani[®]

DESIGN MARIANI DESIGN MARIANI DESIGN MARIANI DESIGN MARIANI
DESIGN MARIANI DESIGN MARIANI DESIGN MARIANI DESIGN MARIANI
DESIGN MARIANI DESIGN MARIANI DESIGN MARIANI DESIGN MARIANI
DESIGN MARIANI DESIGN MARIANI DESIGN MARIANI DESIGN MARIANI
DESIGN MARIANI DESIGN MARIANI DESIGN MARIANI DESIGN MARIANI